

Air Handling Unit RT 250S-EC

OPERATION & MAINTENANCE INSTRUCTIONS

INSTALLATION

CONTROL PANEL

**Easy to
maintain**

**Efficient heat
recovery**

Low noise level

**Low energy
consumption**



Safety page 3
 General/System descriptions page 4
 Principle of operation page 5
 Control panel, structure,
 simple adjustments page 6-10
 Replacing filters, maintenance page 11-13
 Troubleshooting page 14
 Components/Technical data page 15-17
 Wiring diagram page 18

Delivery receipt page 19
 Setting up/Installation/Duct system page 20-21
 Starting up/Adjustment page 22-25
 Maintenance/Serviceing page 26-27
 Troubleshooting page 28

Basics page 29
 Temp. setting for incoming (supply) air page 30
 Changing operating mode page 30
 Afterheater on/off page 30
 Remot panel page 31
 Regulation accuracy - heating page 32
 Heat recovery on or off page 32
 Summer bypass, bypass page 32
 Cooling on or off (optional) page 33
 Settings, cooling page 33
 Resetting filter alarms page 34
 Outdoor air temperature page 34
 Extract air temperature page 35
 Program version page 35
 Adjusting the supply air flow page 36
 Adjusting the extract air flow page 36
 Bypass restriction page 37
 Adjusting the circulation air flow page 37
 External control, input 1 page 38
 External control, input 2 page 38
 Timer functions, channel 1 (optional) page 39
 Timer functions, channel 2 (optional) page 39





Safety

Read through these instructions carefully. Pay particular attention to the safety texts marked with an exclamation mark above. If you use and look after your ventilation unit correctly, it will serve you well for a long time to come. You will enjoy a superior indoor climate while at the same time saving energy thanks to high recovery levels.

Save these instruction carefully. They might be needed in the future.

Installation

Work carried out by laymen may impair the performance of the ventilation unit and cause injury or damage to property. If the unit is adjusted incorrectly, it will not be possible to achieve the desirable benefits such as satisfactory air quality and maximum energy savings.

The unit is heavy. Edges and corners which you would not normally come into contact with may be sharp. Therefore, it is a good idea to wear gloves when moving the unit.



Keep an eye on children. An uninstalled unit may easily tip over under an abnormal load.

Cleaning

Keep the unit clean to ensure maximum performance and a long service life. Filters must be replaced as specified in the instructions. The unit must not be operated without the intended original filters. Operation without filters will have a serious impact on unit performance and may damage the unit's fans and heat exchanger. The intended filters can be ordered from REC Indovent AB,

www.recvent.se

The heat exchanger must be cleaned as described in the instructions. Only detergents designed for use on aluminium may be used.



Alkaline detergents containing ammonia, caustic soda, etc. must never be used as these will corrode the aluminium surfaces and so destroy the heat exchanger.

Service and maintenance

Servicing and repairs, alongside normal maintenance, should be carried out by ventilation specialist or - if electricity is involved - an authorised electrician.



The electric panel must not be opened by anyone other than an authorised specialist.

The protective cover in front of the fan cowlings must not be removed while the unit is operational as this poses a risk of contact with moving parts. Before opening, make sure that the unit is not connected to the mains power supply (the plug is pulled out or the fuse removed).

Working on the system may affect the warranty terms for the unit.

Only use original spare parts.

Scrapping

Prevent accidents when the unit is scrapped. Remove the cable from the wall socket and cut it as close to the unit as possible. Store and transport the scrapped unit lying down. Comply with the instructions of your municipality when dropping off the unit for recycling.

General/Introduction

REC Indovent has been manufacturing Temovex air handling units since the 1970s. User-friendliness has been the order of the day right from the outset. For us, one of the most important things is to make sure our users feel secure and can handle the minimum of maintenance with no fuss. And of course, the fact that you also demand market-leading performance as regards energy consumption and recovery is also a natural consideration in our ongoing development work. Our amassed experience has all been combined to create your Temovex unit.

Temovex units are a quality product made in Sweden, with a long service life and extreme reliability with no unpleasant surprises.

And just to prove that our efforts are taking us in the right direction, Temovex units have won first prize in the Swedish Energy Agency's technology development competition, looking for the best ventilation heat exchanger. The motto for the competition was as follows: "To save energy and the environment with inexpensive, efficient, reliable ventilation heat exchangers".

To ensure your entire ventilation system maintains its performance throughout its entire design service life, you should follow the simple maintenance instructions in this booklet. This unit is designed for continuous operation. It should only be shut down for servicing or inspection.



The unit must never be operated with no filters fitted.

System descriptions

Operation principle The Temovex unit

The Temovex unit consists of fans, air filters, afterheaters and a highly efficient counter-flow heat exchanger developed by ourselves. The counterflow heat exchanger is very well sealed, which prevents odours, contaminants, etc. from coming back into the home. A long service life, low operating costs and a low maintenance requirement are ensured thanks to the use of top quality, reliable components and design solutions involving few moving parts. The thermal energy in the air sucked out of the building is transferred in the heat exchanger to the fresh air coming into the building. The Temovex unit retains the heat or coolness in the building without supplying new thermal energy. (Compare this with a thermos.) Making the most of the thermal energy already present in the building allows the operating time and/or size of the conventional heating system to be reduced. Comfort is also enhanced because the air entering the home is at a temperature nearer to room temperature than it would have been if the air had been taken in directly from outdoors. At the same time, the indoor environment is really enhanced because all the air entering the building passes through a fresh air filter (outdoor air filter). One filter also makes maintenance easy. With Temovex it's easy to access!

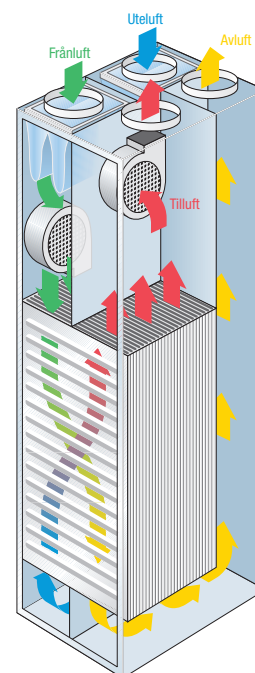

Principle of operation - REC Vent ventilation system

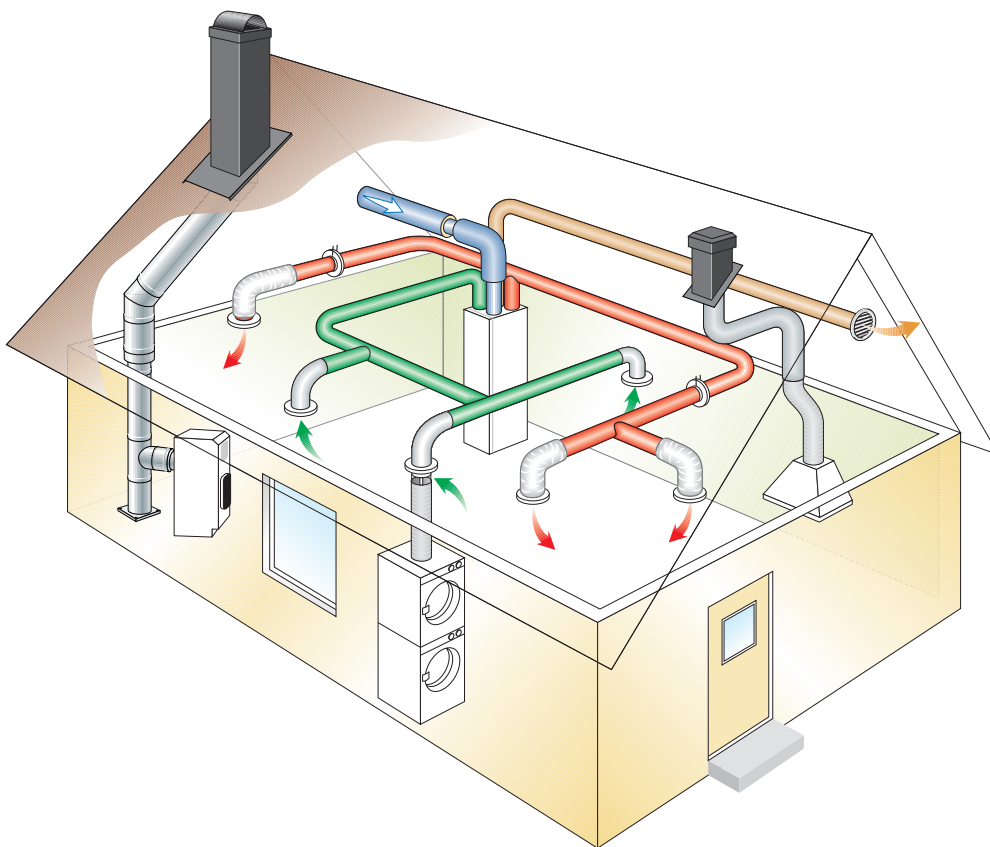

The principle for a balanced ventilation system, with mechanical supply and exhaust air, is really simple.

To get rid of anything that could harm people and/or buildings, we need to remove contaminants and moisture held in the indoor air. This is known as exhaust air (green ducts). This creates underpressure in the building, so new air has to come in.

When mechanical supply air is provided, there is an opportunity to filter the new air and also to check sound incoming from the outside (the blue duct). Mechanical supply air (red ducts) allows you to determine where you want the fresh air to be, in what quantities and at what temperature. Normally you want this air to go to rooms people spend time in, such as bedrooms and living rooms. Well thought out distribution of exhaust/supply air results in a home well ventilated throughout. And you get a more consistent indoor temperature throughout the entire home into the bargain, too. The used air which has now released most of its energy content, is fed out in a separate ventilation duct for extract air (brown duct). Most

commonly, this opens out into a roof hood on the roof, but a wall-mounted wall device can just as well be used. A balanced ventilation system almost always comes with heat recovery.

Temovex units make your home into a thermos! You retain the heat/coolness in the building without supplying new thermal energy. Your heating system will have an easier job to do, and you will be able to adapt it according to "the conditions in the thermos". The kitchen fan is often dealt with entirely separately, with an individual fireproof duct in a roof hood on the roof.

REC Vent is a complete ventilation system, including duct components and planning, supplied by REC. We take overall responsibility for the operation and quality of this system. And so we can guarantee you the results you require.

Contact your building supplier or local ventilation contractor and tell them you want a REC Vent ventilation system. We promise you will be pleased with the results!

Control panel

On the following pages you will find detailed instructions on how to set the unit according to your requirements and wishes. The unit control system optimises its function according to the settings you define.

As a user of the ventilation unit, you will find it useful to be aware of the following:

In menus where you have the option of making changes, "auto mode" gives the most optimised function. If you select a manual setting, On or Off, the manual setting takes precedence over the auto settings. **Push and briefly hold the buttons to implement changes.** You can also hold down a button longer to browse.

The lighting in the display turns on automatically when pushing a button and turns off again after about 1 minute of activity.

Menystruktur

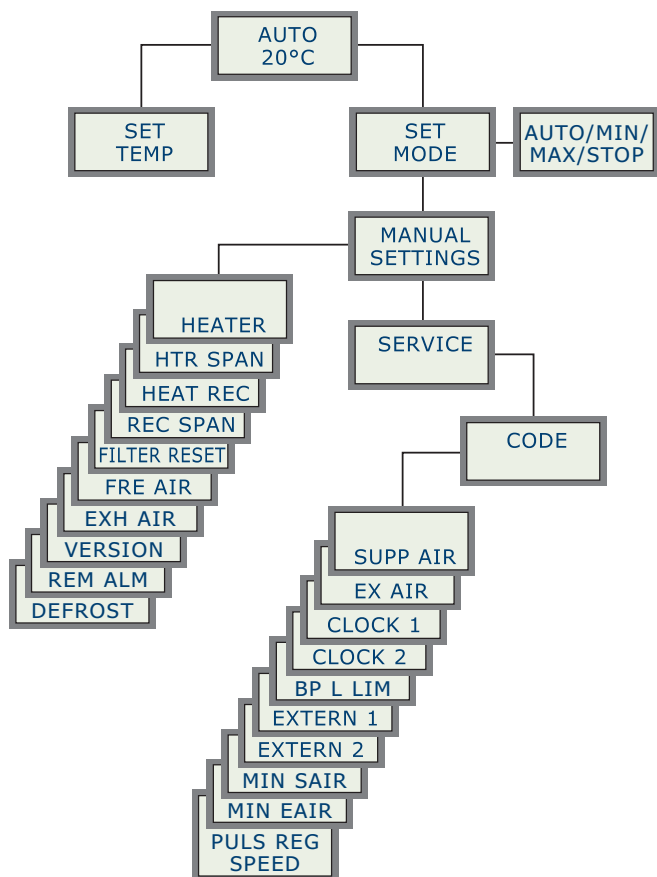

Structure/explanations

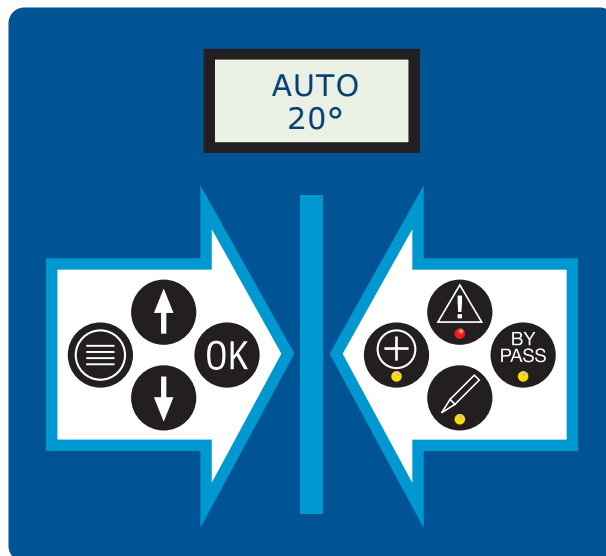

Buttons

- Menu button, press to return to the main menu.
- Arrow up, move up in menus or change mode
- Arrow down, move down in menus or change mode
- OK, confirm selected setting

Indicator lamps och symbols

- Alarm, comes on when an alarm is triggered - look in the display for more detailed information
- Bypass, comes on when the bypass is open (no recovery)
- Afterheater, comes on when the afterheater is heating
- Change mode, comes on when changes can be made

Display

- Fan speed selected
- Air temperature

Starting up/main menu

The display shows:

Line 1: current fan speed, min. flow/auto/max. flow



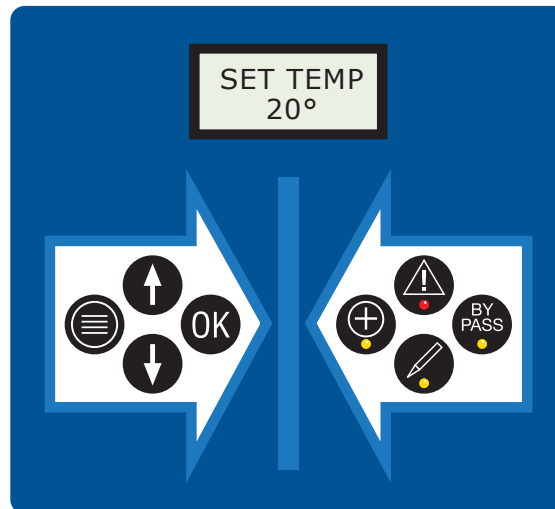

Line 2: actual air temperature in the supply air duct.

Note: As an alternative, sensors can be installed in exhaust air ducts or rooms.









Simple adjustments

Temperature, setting the temperature of incoming air (supply air)









- In the main menu
- Press **Pressure**  **OK**
- The display shows: “SET TEMP” and current setting. The change mode lamp  comes on. Press up  or down  to give the required value is displayed, in increments of 1 °C (set your required room temperature)
- Confirm your selected setting by pressing **OK**. This takes you back to the main menu, and current values are displayed

Changing operating mode, fan speed

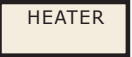
- In the main menu
- Press arrow down  or up  until “SET MODE” appears in the display 
- Confirm by pressing **OK**, AUTO appears in the display.
- The change mode lamp  comes on. Use arrow up  or down  to switch between auto/min flow/max flow/stop system.
- Confirm your selected setting by pressing **OK**. This takes you back to the main menu.

Extended adjustments

Afterheater on/off (automatic if so required)

- In the main menu
- Press arrow down  up  until “MANUAL SETTINGS” appears in the display. 
- Confirm by pressing **OK**, “HEATER” appears in the display 
- Confirm by pressing **OK**. The current setting appears in the display. The change mode lamp  comes on. Use arrow up  or down  to choose between on/off (AUTO/OFF) 
- Confirm your selected setting by pressing **OK**.
- Press the menu button  to go back to the main menu.

Remote panel (option)

When the remote panel is connected, the text in the unit's control panel changes to "REMOTE".

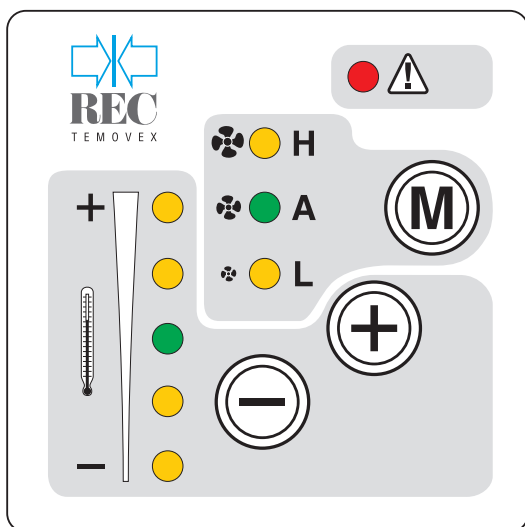

Structure/descriptions

⚠ The alarm LED indicates filter change.

(M) = Change fan speed: Auto, High or Low

(+) = Increase the temperature of supply air

(-) = Decrease the temperature of supply air

Temperature adjustment

By pressing (+) or (-) you can adjust the temperature of the supply air a few degrees up or down in relation to the setting in the unit's main panel.

Alarm indication













You can choose whether you want to have alarm indication on the unit or on the remote panel. When you switch on the power to the unit, the alarm lamp flashes once if alarms are displayed on the remote panel. To change, the M button must be depressed at the same time as the power is switched on. 3 flashes: Alarms on remote panel are off. 4 flashes: Alarms on remote panel are on. To reset the filter alarm from the remote panel, push and hold (M) and (-) (minus) at the same time; the lamp will flash 6 times.

Alarm indication on unit













- On the main menu
- Press the down (↓) or up (↑) until the display shows "MANUAL SETTINGS". MANUAL SETTINGS
- Confirm with (OK).
- Press the down (↓) or up (↑) until the display shows "REM ALM". REM ALM
- Confirm with (OK).
- Displayen visar nuvarande inställning. The current setting is shown on the display. The change mode lamp (💡) comes on. Use the up/down arrows (↑/↓) to choose between YES/NO. NO provides indication on the unit. YES provides no indication on the unit.
- Confirm your selected setting with (OK).
- Press the menu button (☰) to return to the main menu.

Note: Through a combination of settings on the unit and/or remote panel, a situation can arise in which alarms are not displayed on either unit.

Regulation accuracy, afterheater

- In the main menu
- Press arrow down  or up  until “MANUAL SETTINGS” appears in the display 
- Confirm by pressing .
- Press arrow down  once until “HTR SPAN” appears in the display 
- Confirm by pressing .
- The current setting appears in the display. The change mode lamp  comes on. Use the arrows up/down  to change the value by 1-5 °C. State the deviation from set room temperature in “SET TEMP” before the afterheater is activated. (4 °C is recommended, e.g.: you require 21 °C indoors. So you set this value to 4.) 
- Confirm your selected setting by pressing .
- Press the menu button  to go back to the main menu.





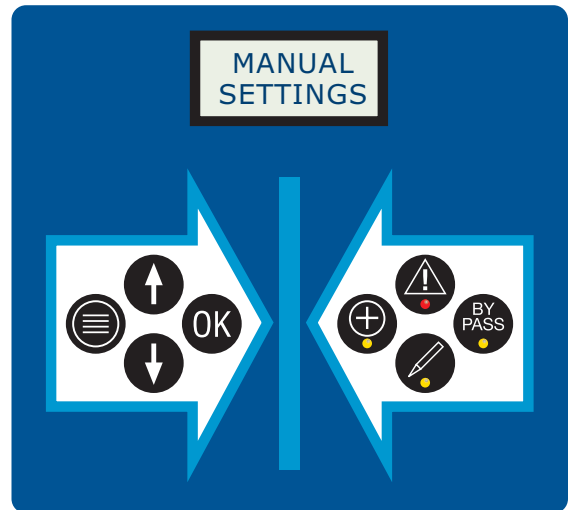







Heat recovery on or off

- In the main menu
- Press arrow down  or up  until “MANUAL SETTINGS” appears. 
- Confirm by pressing .
- Press arrow down  twice until “HEAT REC” appears in the display 
- Confirm by pressing .
- The current setting appears in the display. The lamp change mode lamp  comes on. Use the arrows up/down  to choose from on/off/auto (ON= heat recovery always on, OFF= heat recovery always off, AUTO= optimises the function guided by selected temperature settings) 
- Confirm your selected setting by pressing .
- Press the menu button  to go back to the main menu.



Setting summer bypass (bypass)

(Cooling recovery: Bypass closes to reuse subnormal temperature when the outdoor temperature exceeds the settings SET TEMP + REC SPAN)

- In the main menu
- Press arrow down  or up  until “MANUAL SETTINGS” appears.: 
- Confirm by pressing .
- Press arrow down  three times until “REC SPAN” appears in the display 
- Confirm by pressing .
- The current setting appears in the display. The lamp change mode lamp  comes on. Use the arrows up/down  to change the value by 1-5 °C. Specifies the deviation from the set room temperature in “SET TEMP” before the bypass opens (3 °C is recommended, e.g.: you require 21 °C indoors. So you set this value to 3.) 
- Confirm your selected setting by pressing .
- Press the menu button  to go back to the main menu.

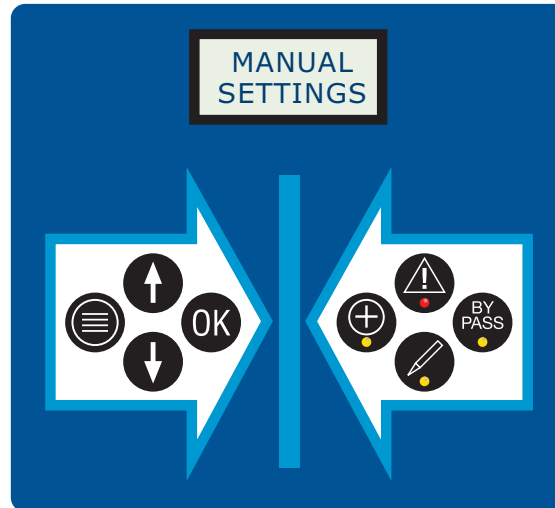

(when the cooling option is available, the menus “HEAT REC” and “REC SPAN” are replaced with settings “CHILLER” and “CHILSPAN” for cooling) Note: Unit fitted with the option chiller has no bypass.

Cooling on or off, optional

- In the main menu
- Press arrow down or up until “MANUAL SETTINGS” appears in the display
- Confirm by pressing .
- Press arrow down or up until “CHILLER” appears in the display
- Confirm by pressing .
- The current setting appears in the display. The lamp change mode lamp comes on. Use the arrows up/down to choose from off/auto (OFF = cooling is never activated, AUTO = optimises the function according to the selected temperature settings) ON = cooling always on
- Confirm your selected setting by pressing .
- Press the menu button to go back to the main menu.

Settings – cooling

- In the main menu
- Press arrow down or up until “MANUAL SETTINGS” appears in the display
- Confirm by pressing .
- Press arrow down or up until “CHILSPAN” appears in the display
- Confirm by pressing .
- The current setting appears in the display. The lamp change mode lamp comes on. Use the arrows up/down to change the value from 1-5. Specifies the deviation from the set room temperature in “SET TEMP” before cooling is activated (2 °C is recommended)
- Confirm your selected setting by pressing .
- Press the menu button to go back to the main menu.

Maintenance

The information in the main menu in the control panel may be replaced by alarm texts in order to provide a simple, user-friendly overview (in the event of any problems). These alarms are:

- **HEATER ALARM** = overheating in the afterheater.

The fans stop.

(In the case of afterheater water - frost protection alarm)

This alarm is reset by shutting down the unit using the main switch on the unit control panel. Leave the power off for approx. 3 min.

If the alarm recurs, contact a service engineer or installer. For more information, see "Troubleshooting".

Another alarm text may appear:

- **FILTER ALARM** = the filter replacement interval has been exceeded (6 months). Resetting/acknowledgement is described further on in this booklet.

New filters can be ordered from www.recvent.se or by calling REC Indovent AB, +46 31 67 55 00.

REC Indovent AB also provides a subscription option for filters. All you have to do is decide how often you want to replace your filters, we do the rest. The filters will be sent to your home by post.

- It really couldn't be easier!

Subscribe at www.recvent.se today! State your product serial number and we will give you your first batch of filters free (subject to subscription to our service on the website).

Renew filter

There are two filters in the Temovex unit: an exhaust air filter and an outdoor air (fresh air) filter.

These filters should be replaced twice a year, or once a year as a minimum. The filters must not be washed - they must be replaced with new ones. Contact REC Indovent AB, +46 31 67 55 00, or see www.recvent.se to order filters.

- Open the door on the unit
- Switch off the power supply to the unit using the main switch
- Undo the long cover. Take hold of the filter and pull the front edge backwards and down
- Behind the internal cover is the outdoor air (fresh air) filter. Remove this as well.
- If necessary, clean all accessible surfaces.
- Fit the new filters in reverse order. (The pink - outdoor air filter is fitted in the back)
- Refit the cover
- Switch on the power
- Close the door to the unit.





The unit can be used if the filters are dirty, but its performance will be impaired. Energy consumption will increase and heat recovery will be reduced.

Note: When heat recovery is reduced, there is a risk of greater energy consumption to power the afterheater during cold periods.



The unit must not be used without filters.

Resetting the filter alarm

- In the main menu
- Acknowledge the filter alarm by pressing **OK**.
The text in the display and the lamp goes out. Recurs at 7-day intervals.
- Press arrow down **↓** or up **↑** until "MANUAL SETTINGS" appears in the display. 
- Confirm by pressing **OK**.
- Press arrow down **↓** or up **↑** until "FILTER RESET" appears in the display. 
- Confirm by pressing **OK**.
- The display shows: "NO". Use the arrows **↑** **↓** to select "YES" (replacement interval every 12 months)
- Confirm your selected setting by pressing **OK**.
- Press the menu button  to go back to the main menu.

Cleaning the fans

- Switch off the power using the main switch
- Open the door on the unit
- Remove both covers.
- Undo the quick-action contact on the fan and pull out the fan coil. (Do one fan at a time)
- Clean the impeller using a brush or compressed air.
- Refit the fans in reverse order.
- Refit the covers.
- Close the door to the unit
- Switch on the power using the main switch.

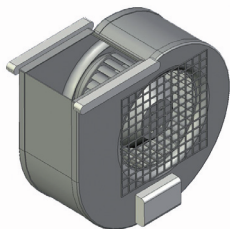

 Under no circumstances must the motors be cleaned under running water.

Cleaning the heat exchanger

- Switch off the power using the main switch.
- Open the door on the unit
- Remove both fans as described above.
- Open the service hatch at the bottom of the cabinet.
- Remove the red plug at the bottom of the unit, the condensation drain.
- Flush the heat exchanger with hot water.



Note: If the unit is fitted with a condensation evaporator unit (kavk), a wet vac is used to deal with the rinse water. A degreasing agent may be required if the heat exchanger is very dirty.

 Must be of a type which is not aggressive to aluminium.

- Where necessary, repeat the procedure once more.
- Refit the red plastic plug. (This must be on the same side as the filters.)
- Refit the inspection hatch and fan motors in reverse order.

 Take care to make sure the fan motors are not/do not get wet when restarting the unit- This could be fatal!

- Close the door to the unit.
- Switch on the power using the main switch

Checking the condensation drain

- Open the door on the unit.
- Open the service hatch at the bottom of the cabinet
- Check the drain to make sure it is not blocked. This can be done by pouring a little water into the bottom of the unit, for example. Note: Only on the side without the red plastic plug
- In the event of a stoppage, try to move the obstruction. Where necessary, call an engineer or plumber.
- Refit the service hatch
- Close the door to the unit.

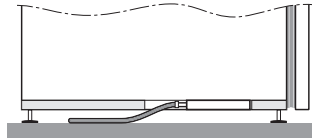

Cleaning the air diffusers

The building's ventilation devices must be cleaned regularly in order to maintain correct ventilation. Use a dry cloth and/or a small brush in order to get into the ventilation outlet on the device. Where necessary, the device can be taken down to facilitate cleaning. The dirty mark which may appear on the ceiling near to the device can most easily be removed using a feather duster or dry cloth.



Note: The device settings must not be changed. Do not confuse the devices if you take down a number of devices at the same time.

Cleaning the duct system

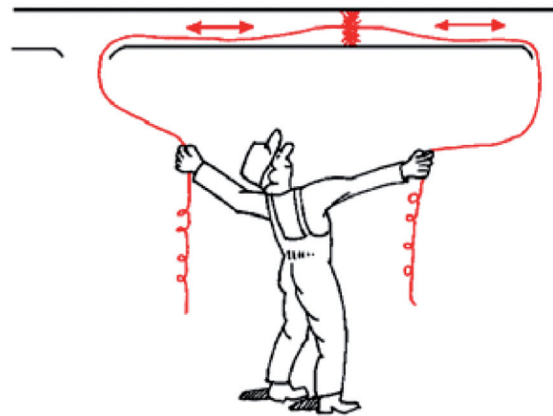

The exhaust air ducts - and sometimes the supply air ducts as well - may need to be cleaned after a fairly long period of use. Dust and dirt collect there over time, and this can impair the system capacity.

Authorised ventilation cleaners should be called to carry out cleaning. However, the occupant can easily clean the first part of the system inside the device. Remove the device, then use a vacuum cleaner and - where appropriate - a feather duster to clean the bits you can get at.

Take care not to change the device settings. Refit the device in the same location.

Note: Shut down the unit when cleaning devices or ducts.

Checking - outdoor air intake

It is a good idea to check the outdoor air intake once a year or so. Check that it is not blocked and that there is nothing obstructing it, such as leaves or snow/ice.

Installation instructions for duct enclosure for RT 250S-EC

General information

The duct enclosure is a lacquered assembly for the Temovex unit RT 250S. It is constructed as a telescoping hood with an upper and lower section to fit all ceiling heights between 2.3 and 2.70 m. REC recommends that a gap of 5 mm be left against the ceiling so as to avoid the transfer of vibrations.

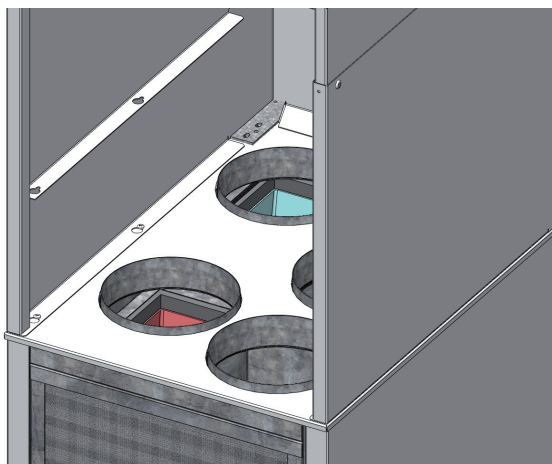
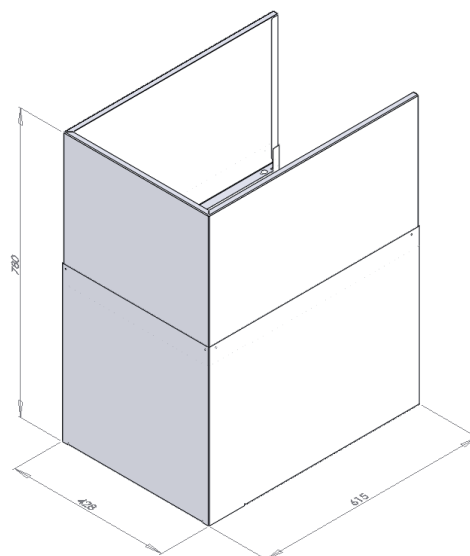

1. First measure the distance to the ceiling. Now join the upper and lower sections on a flat and level floor. Make the duct enclosure about 5 mm shorter than the distance to the ceiling. The holes in the upper section's cover plate (the smaller of the two plates) are made with the supplied self-tapping sheet metal screws. Now secure the upper section with the 4 **white** sheet metal screws to attain a white surface.

2. Lift the assembled duct enclosure up onto the unit. Ensure that the 4 screw heads are positioned in the respective key holes. Secure the duct enclosure by pressing it backward about 5 mm as shown in the figure above.
When fitting the duct enclosure afterwards, when it was not initially ordered, the pop rivets on the top of the unit must be replaced with screws.

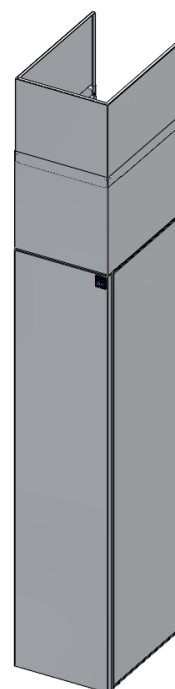

3. For service and access to the unit's top, the duct enclosure assembly is only lifted off in one piece (according to point 2, in the reverse order).

Troubleshooting

1. “Filter alarm” appears in the display and the alarm lamp comes on

- a. Replace the filters and reset the filter alarm as described in an earlier instruction: see page 9.

2. The fan (fans) is (are) not running

- a. Check which fan is not running on the display. If there is power to the unit, continue as follows.
- b. If you think that any of the fans’ built-in overheat protection devices have tripped, shut off the power using the main switch on the unit. Wait approx. 1 minute before you switch the power back on again.
- c. Check that the plug is fully inserted; both into the wall and between the fan motors and the unit.
- d. If the fan (fans) is (are) still not running, or if they stop again after a short period of operation, contact a service engineer.
- e. Check that the unit fuse is unbroken.
- f. That the earth circuit breaker has not tripped.



2. Cold supply air

- a. Check that the bypass is not set to remain open constantly – set “heat recovery” to auto mode.
- b. Check that the exhaust air filter is not extremely dirty. – Where required, replace the filters.
- c. Check that the afterheater is not shut off – set the afterheater to AUTO.
- d. Check the temperature settings as shown in the instructions earlier on in this booklet.
- e. If the unit is fitted with the Cooling option,
 - Check its settings.

3. Low air quantity

- a. Check that the unit is operational. Check that the relevant fan is running.
- b. Check the settings for fan speed “SET MODE” – set to auto mode.
- c. Ensure that no external regulations/switches are affecting the fan speed.
- d. Check the air intake and roof hood. Clear away any dirt, snow, etc.
- e. Clean the fans and the heat exchanger where appropriate.
- f. If the devices or duct system are dirty
 - clean if necessary.
- g. Check that the duct system has not been deformed (during renovation or similar)



4. Water leaks

- a. Check that the condensation drain is connected to/is able to discharge to a floor drain.
- b. Check that there is no blockage in the condensation pipe from the unit.
- c. Check that the red plug inside the unit service hatch (lower part) is on the correct side. This should be on the same side as the filters. If the unit is fitted with a condensation evaporator unit (kavk), there is a plug in both holes.

5. Humming or noise from the unit

- a. Check whether any of the fan impellers is very dirty or otherwise damaged.
- b. If any of the impellers is dirty, this may cause imbalance – noise. Clean as described in the instructions.



6. Text alarm + alarm lamp

HEATER ALARM = overheating in the afterheater.

- Reset the heater’s internal overheat protector by switching off the power to the unit for approx. 3 min. Use the main switch on the unit. If the fault persists, contact a service engineers. The fans stop.
- Water afterheater, check that there is heat in the system and that the circulation pump is running. Reset the alarm by powering down the unit using the main switch for approx. 3 min.
- Check that the filters are not full of dirt and that the outdoor air intake is not blocked. The extract air (roof hood) may also need to be checked.
- Check the setting on the external thermostat GT7.

7. Sensor Error

If the duct sensor GT1 registers an incorrect or excessively deviating value, “Sensor Error” is shown on the display. The unit will subsequently stop regulating in relation to temperature until the error is corrected.

The status of outdoor air sensor GT11 is shown on the display under manual settings. In the same way, the value is displayed for GT3 (exhaust air sensor).

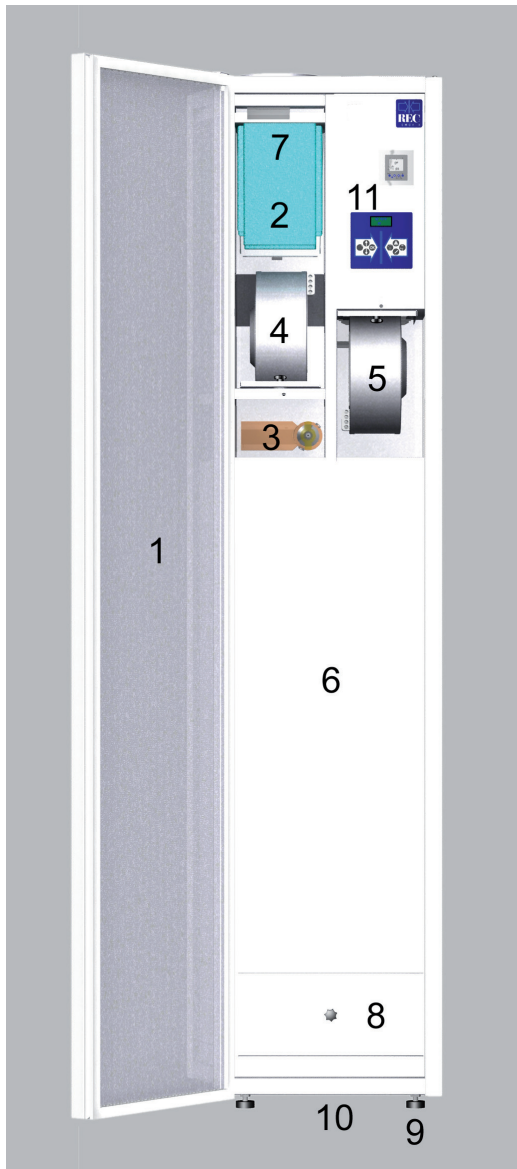

Placement guide

1. Door with magnetic strip
2. Exhaust air filter
3. Bypass valve
4. Exhaust air fan
5. Supply air fan
6. Heat exchanger
7. Outdoor air filter (behind hatch)
8. Inspection hatch
9. Adjustable feet
10. Condensation drainage
11. Control panel

Note: The diagram shows the model with the door suspended on the left

Functional diagram

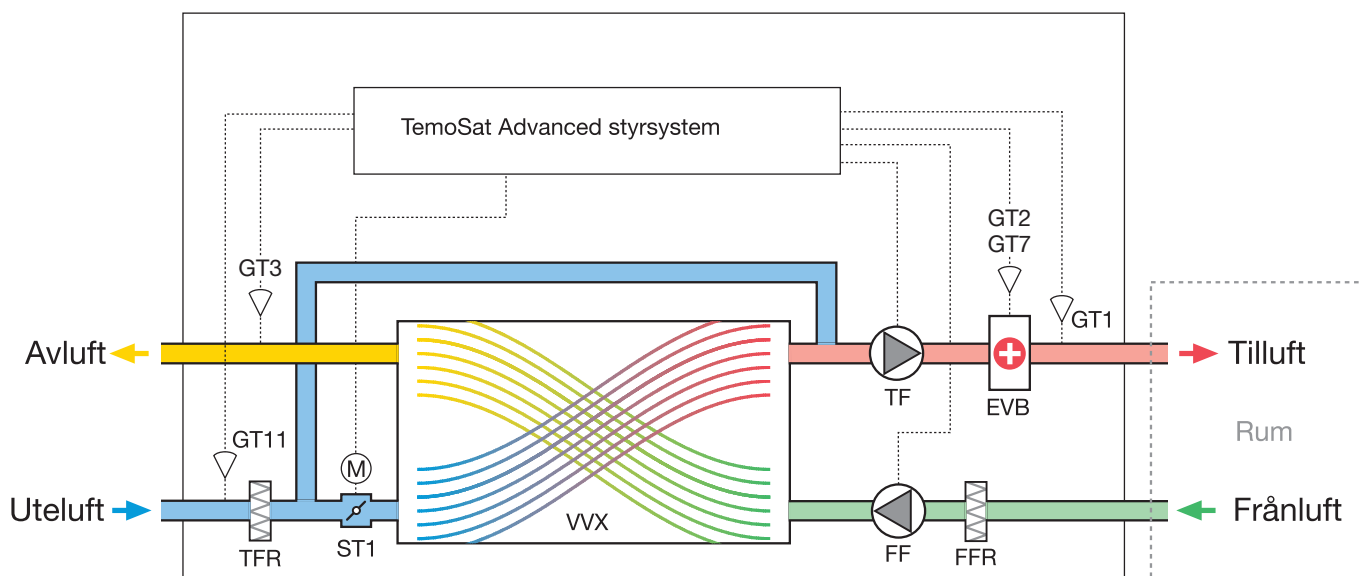

- | | |
|--|---|
| VVX – Counter-flow heat exchanger | FFR – Exhaust air filter |
| ST1 – Damper motor, heat recycling (Bypass) | TF – Supply air fan |
| EVB – Heating battery electricity/water | FF – Exhaust air fan |
| GT1 – Duct air sensor | GT2 – Overheating protection, residual heat |
| GT11 – Outdoor temperature sensor | GT3 – Exhaust air temperature sensor |
| TFR – Supply air filter (outdoor air filter) | GT7 – Ice protection sensor (water battery) |

Cooling battery (option)

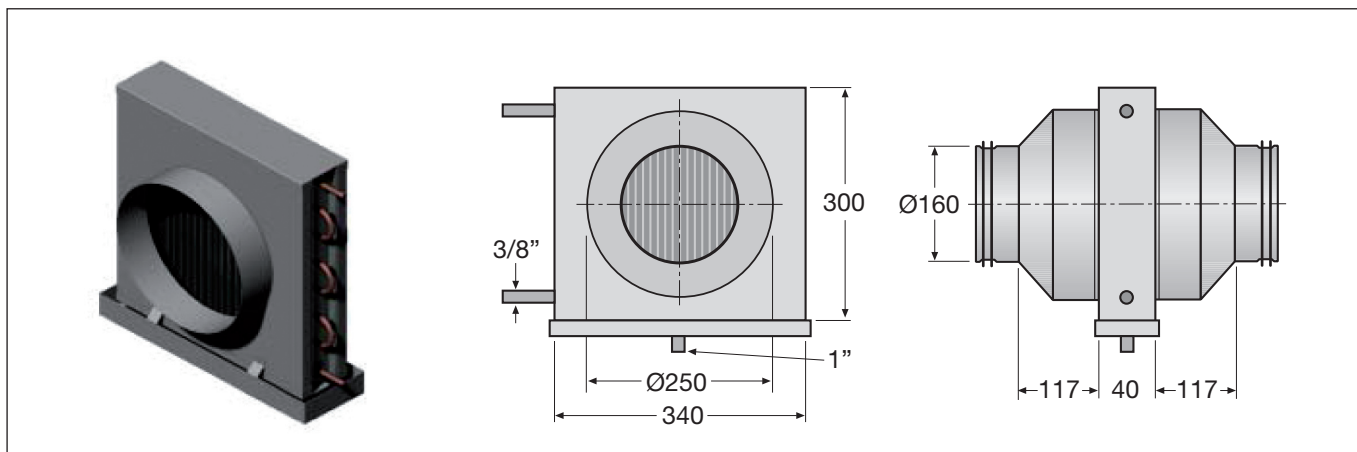

Technical Specifications

	Electrical version	HW version water temp. 55/45°C
Rated output, unit	1034 W	134 W
Rated output, heater	900 W	1200 W, (2000 optional), internal
Rated output, fans	2 x 67 W	2 x 67 W
Voltage/Frequency	230 V, 50 Hz	230 V, 50 Hz
Fuse	10 A	10 A
Filter SA/EA	Bag F7/bag G3	Bag F7/bag G3
Weight	100 kg	100 kg
Water connection	X	DN12
Fire classification	A15	A15
Dimensions (BxDxH)	430x620x1900 mm	430x620x1900 mm
Duct connections	4 x Ø160 mm	4 x Ø160 mm
Condensation drain	3/4"	3/4"

Dimensions

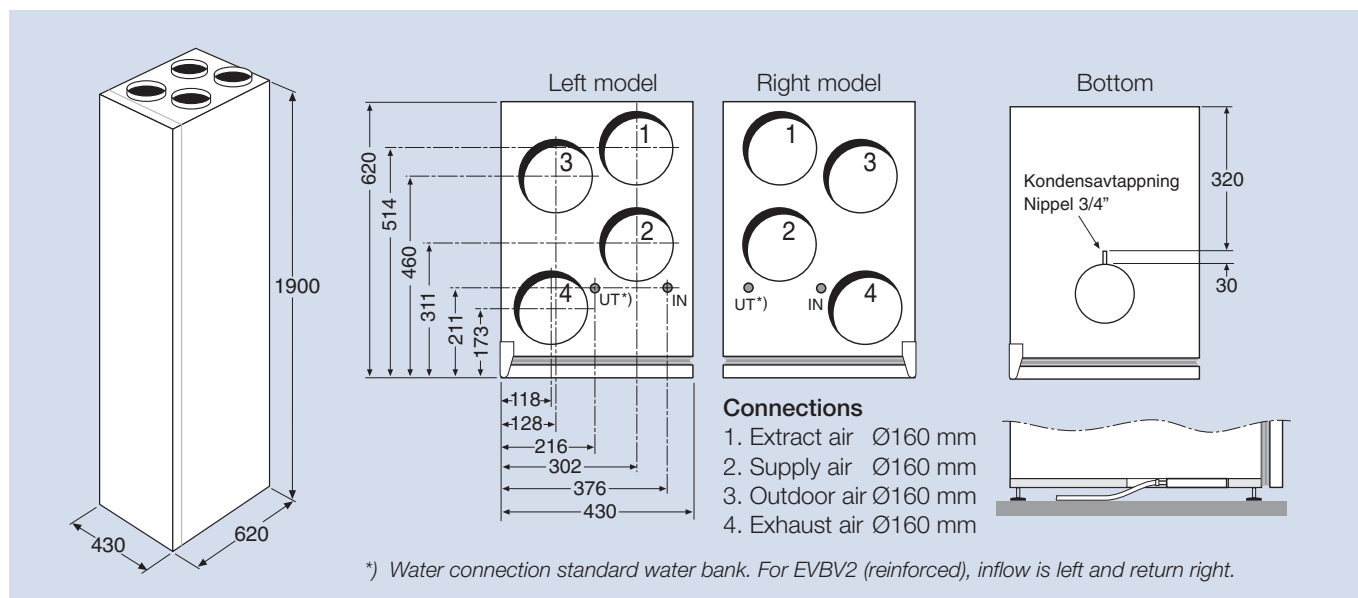

For the installer

Delivery receipt

Check that the number of packages matches the delivery note and that no damage has been sustained in transit. The ventilation unit must be stored indoors. If possible, the unit is stored lying down in order to minimise the risk of injury if it tips, for example. Pay particular attention to this point if there are any children nearby.

General description

The RT 250S-EC is a unit (compact cabinet) designed for the ventilation of homes, offices, nur-series or other small premises. The Temovex is designed to be placed in heated rooms such as a laundry room, boiler room, corridor or similar. This unit is made up of double plates with insulation between them; and it also includes a counterflow heat exchanger, two fans, exhaust air and supply air filters, an electric after-heater, and automatic bypass and the Temosat Advanced control system. The counterflow heat exchanger has been developed by ourselves and is the result of 30 years of experience of highly efficient counterflow heat exchangers. The RT 250S-EC is available in right and left hand models.

Casing

Made of hot galvanised sheet metal with 30 mm of insulation between the sheets. The sides and front are supplied in a white powder paint finish as standard. A large, full door/inspection hatch in the front which closes with the aid of a magnetic strip. All duct connections take place on top of the unit and are executed as sleeve connectors. The cabinet is fitted with adjustable rubber feet.

Heat exchanger

The Temovex heat exchanger is made up of aluminium sheets. The structure is fully sealed between the supply air side and the exhaust air side. There is no seepage of odours or contaminant between the old air and the new. The design also means that wear parts are now down to a minimum.

Bypass

The Temovex unit is fitted with an automatic bypass which is regulated by the settings in the control panel. The bypass is not included when the EKB free cooling option is fitted.



Condensation drain

The Temovex unit is fitted with a condensation drain at the bottom of the unit, 3/4". This has to be connected to a drain or fed to a floor drain. **The condensation pipe does not need to be fitted with a water trap.** The condensation pipe has to be connected when the unit is installed! If the unit is fitted with the optional condensation evaporator (kavk), no external connection is required.

Fans

Low-energy fans are of EC type. These fans have a broad working range and work with constant flow ("cruise control") which compensates for filter blockage, etc. The fan motors come with integrated overheat protection devices which cut the power and stop the fan. Reset by shutting off the power to the fan motor for approx. 1 min. Use the main switch in the control panel.

Afterheater

The RT 250S-EC is fitted with an electric afterheater, 0.9 kW. A reinforced electric afterheater, 1.8 kW, or a water coil for waterborne heating, 1.6 kW, is offered as an optional extra. The heater is integrated into the unit, and settings and control are executed using the Temosat Advanced control panel.

In the case of a water coil, the water connections are on the top of the unit, dimension DN12. The RT 250S-EC with a water coil includes a two-way valve and valve motor in the consignment from REC.

Filter

Exhaust air filter, G3, bag (art. no. Q120101)
Supply air filter, F7 bag (art. no. Q120100)

Temosat advanced

All settings for fan speed, afterheater, bypass, etc. are implemented via the integrated control panel. The factory-fit options and their parameters are also adjusted using the control panel.

Electrical connection

The unit is connected to an earthed socket using the plug fitted. The power is fed to the top of the unit. The wall socket has a 230 volt, 50 Hz power supply and is protected by a 10 A fuse.

For the installer

Setting up/Installation/Duct system

The ventilation unit is fitted standing up in boiler room or similar. If the unit can be placed approx. 10 mm away from an inner or outer wall, this is a plus in order to minimise the chances of structural-borne noise. We also recommend that the walls of surrounding rooms be fitted with airborne sound insulation. These cautionary measures should be implemented even though Temovex units are generally very quiet. The unit is fitted with adjustable rubber feet, and the fan motors are damped well.

When positioning the unit, it must be borne in mind that the unit requires regular inspection. Make sure that it is possible to fully open the door in the front of the unit. The unit must be positioned such that it cannot be splashed with water during operation. As an option, the unit can be equipped with protection that enables the installation to comply with IP class X5.

Condensation drain

The Temovex unit is fitted with a condensation drain at the bottom of the unit, ¾". This has to be connected to a drain or fed to a floor drain. **The condensation pipe does not need to be fitted with a water trap.** The condensation pipe has to be connected when the unit is installed!

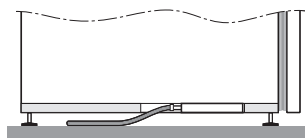

If the unit is fitted with the optional condensation evaporator (kavk), no external connection is required.

Duct system, general

Ducts and duct details should be made from an age-resistant material which is also easy to clean inside. For shorter fittings between the roof hood and duct system, for example, a flexible duct known as a "drasuten" can be used.

Tumble dryers and drying cabinets must not be connected directly to the duct system. Pull switches must be used.

Outdoor air and extract air

The outdoor air intake, YGAV, is best positioned on the north or east side of the building, slightly raised from ground level so as to avoid contaminants near to

the ground. The outdoor air intake should be placed at a distance from kitchen flues, exhausts from central vacuum cleaners, etc.

Extract air should be passed out over the roof via a roof hood, VHS. In some cases a combined air terminal device (KD) or combination hood (VHS kombi) can be used.

Fitting a duct system

Ducts and duct details are fitted in accordance with the instructions of the selected supplier, normally using three pop rivets or special assembly screws in each joint. If duct details with rubber seals are used, no additional joint sealing is required.

Temperature sensor location

Duct sensor GT1 is placed in the supply air duct, and GT11 is placed in the outdoor air duct and G3 is placed in the extract air duct. Remember to seal the leadthroughs carefully.

Strap-on temperature sensor GT7, ice protection at water heater, is clamped against the return line from the water coil. Recommended settings 2 - 5 C.

If a simpler form of extract air regulation is required, GT1 is placed in the extract air duct instead.

If the EKB (cooling) option is fitted, the sensor GT1 must be placed in the extract air duct.

Note: The settings for how heating and the bypass work then have to be changed! The temperature span must be narrower, such as 1 for HTR SPAN and 2 for REC SPAN.

Insulation

Outdoor air and extract air ducts in heated spaces must be insulated against condensation along their entire length using min. PE30 insulating sleeve.

The diffusion barriers are sealed using ventilation tape. Supply air and exhaust air ducts laid in warm rooms do not need to be insulated against condensation, although heat insulation may be appropriate. To be decided in each individual case.

If the supply air and exhaust air ducts are laid in cold or unheated rooms, they must be insulated against heat. If blanket insulation is used, two layers with displaced joints should be achieved, with a total minimum insulating thickness of 120 mm. If loose-fill insulation is being laid, the layer covering the ducts must be at least 150 mm.

For the installer

Setting up/Installation/Duct system

Silencing

On the unit (or early in the duct system), silencers designed for the installation are fitted. This applies to both supply air and exhaust air ducts. Under certain circumstances or in some installation environments, silencers on the outdoor air and extract air ducts may be relevant.

Flexible silencers (aku-comp) are ideal for use in the connection between device and duct. These silencers also prevent what is known as eavesdropping between different rooms interlinked with the same part of the duct system.

Air terminal device

Supply air devices are normally wall or ceiling mounted in rooms where people spend time. Rooms intended for long-term occupation, such as bedrooms, living rooms, etc.

Exhaust air devices are normally wall or ceiling mounted and placed in what are known as “damp and smelly rooms”, such as bathrooms, toilets, laundry rooms, etc.

These devices are fitted so that they can be easily removed for cleaning/servicing or inspection of the duct system.

Excess air between rooms

To facilitate the circulation of air in the home, the air has to be given the opportunity to move from rooms containing supply air to rooms containing exhaust air. Use doors with an excess air gap, or doors without a doorsill (min. 70 cm² free area/exhaust air device). Alternatively, wall mounted excess air devices can be used instead.

Open fireplace

Most modern fireplaces and suchlike have a separate outdoor air connection which provides the grate with combustion air. If this is not available/possible, a separate outdoor air device needs to be fitted. The fireplace consumes air at a rate of 150-300 m³/h. This is equivalent to an air intake of approx. 300 cm²/fireplace.

To facilitate matters when starting a fire (lighting, the fireplace hatch is ajar) in the fireplace, the Temovex units can be provided with the optional “fire function”.

Kitchen flue

The cooker fan is fitted with a separate fireproof spiral duct. The extract air is fed out via a roof hood (VHS). The link between the cooker hood/kitchen fan and the kitchen flue is made using approved KF hose and two quick-action clamps (SBF).

Electrical connection

At the time of delivery, the unit is fitted with a connecting cable approx. 1 m long and provided with an earthed plug. 230 volts, 50 Hz and 10 A fuse.

Connection takes place via the top of the unit.

For the installer

Starting up/Adjustment

Control panel, Temosat Advanced

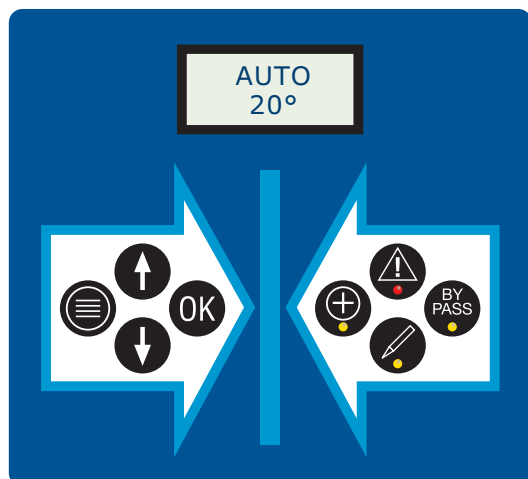

Buttons

- Menu button, press to return to the main menu.
- Arrow up, move up in menus or change mode
- Arrow down, move down in menus or change mode
- OK, confirm selected setting

Indicator lamps and symbols

- Alarm, comes on when an alarm is triggered - look in the display for more detailed information
- Bypass, comes on when the bypass is open (no recovery)
- Afterheater, comes on when the afterheater is heating
- Change mode, comes on when changes can be made

Display

- Fan speed selected
- Air temperature

Starting up/main menu

The display shows:

Line 1: current fan speed, min. flow/auto/max. flow system stopped.

Line 2: actual air temperature in the supply air duct.

Note: As an alternative, sensors can be installed in exhaust air ducts or rooms.

Adjustment - Quick guide

Control voltage V	Capacity %	Air flow l/s	External pressure Pa
1,72	min	17	75
2,16	20	25	75
4,35	40	35	75
5,43	50	45	75
6,5	60	53	75
8	75	63	75
9,23	85	70	75
10	max	75	75

The table above provides a guide to settings when commencing adjustment work. The values for flow and pressure are approximate.

Based on the projected air flows for the system as shown in the drawings and the table above, initial rough setting takes place.

Bear in mind that the fans regulate flow, i.e. they compensate for an increase in pressure drop.

Duct systems and device settings must attempt to achieve as low a pressure drop as possible so as not to increase energy consumption for the fans unnecessarily.

Very low SFP values can be achieved with a well designed duct system and good adjustment.

For the installer

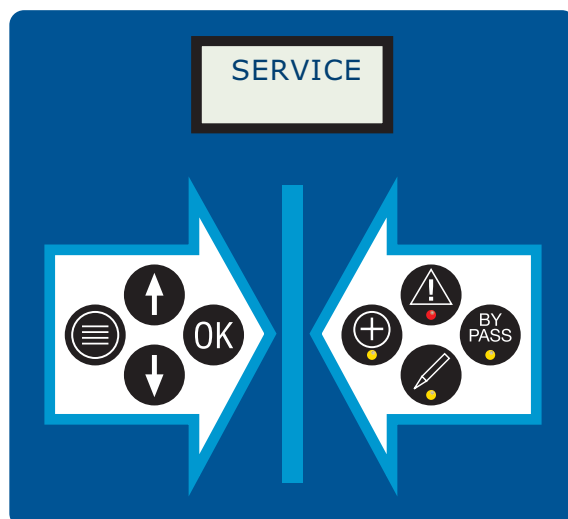

Adjusting the supply air flow

- In the main menu
- Press arrow down or up until "SERVICE" appears in the display
- Confirm by pressing .
- "CODE xxx" (3 digits) appears in the display
- Enter service code **253** by pressing the up/down buttons . Confirm by pressing .
- Note: If you enter the wrong code, you will be returned automatically to the "SERVICE" menu.
- If you enter the correct code, "SUPP AIR" appears in the display
- Confirm by pressing .
- The current setting appears in the display. The lamp change mode lamp comes on. Use arrow up/down to specify as a percentage of maximum how much supply air is planned.
- Confirm your selected setting by pressing .
- Check the new flow over the devices. If necessary, adjust the capacity again.
- If the extract air flow also has to be adjusted, use the arrow keys to access "EX AIR" in the display. Otherwise the procedure is the same as for the supply air flow. If adjustment is complete, press the menu button to go back to the main menu.

Adjusting the extract air flow

- In the main menu
- Press arrow down or up until "SERVICE SETTINGS" appears.
- Confirm by pressing .
- "CODE xxx" (3 digits) appears.
- Enter service code **253** by pressing the up/down buttons. Confirm by pressing .
- Note: If you enter the wrong code, you will be returned automatically to the "SERVICE" menu.
- If you enter the correct code, "SUPP AIR" appears in the display
- Press arrow down or up until "EX AIR" appears in the display
- Confirm by pressing .
- The current setting appears in the display. The lamp change mode lamp comes on. Use arrow up/down to specify as a percentage of maximum how much exhaust air is planned.
- Confirm your selected setting by pressing .
- Check the new flow over the devices. If necessary, adjust the capacity again.
- If the supply air flow also has to be adjusted, use the arrow keys to access "EX AIR" in the display. Otherwise the procedure is the same as for the exhaust air flow. If adjustment is complete, press the menu button to go back to the main menu.

For the installer

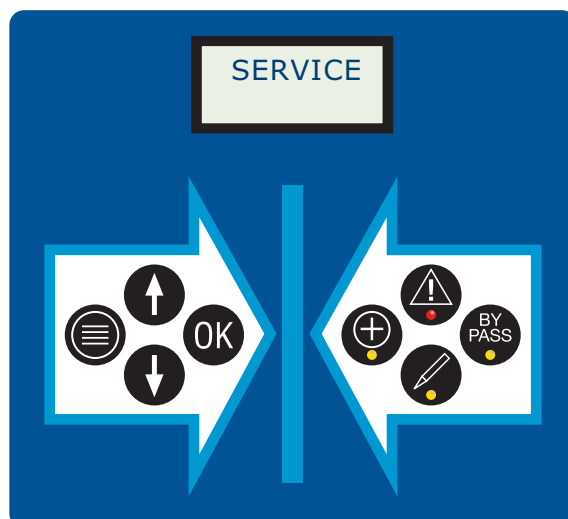

Pulse regulation (option)

- On the main menu
- Press arrow down or up until "SERVICE" appears in the display
- Confirm by pressing .
- "CODE xxx" (3 digits) appears in the display.
- Enter service code **253** by pressing the down button .
Confirm by pressing .
- Note: If you enter the wrong code, you will be returned automatically to the "SERVICE" menu.
- If you enter the correct code, "SUPP AIR" appears in the display
- Press arrow down or up until "PULS REG SPEED" appears in the display.
- Confirm by pressing .
- The current setting appears in the display.
lamp change mode lamp comes on.
Use arrow up/down to choose between 1–10;
1 provides rapid regulation (suitable for supply air regulation) and 10 significantly slower.
- Confirm your selected setting by pressing .
- press the menu button to go back to the main menu.

For the installer

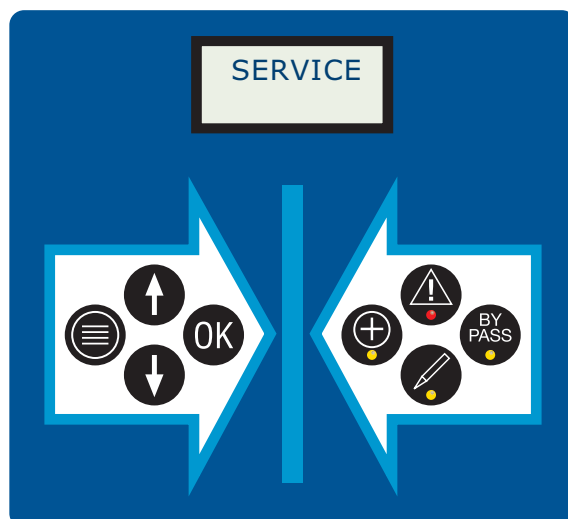

Adjusting supply air minimum flow

- In the main menu
- Press arrow down or up until "SERVICE" appears in the display.
- Confirm by pressing .
- "CODE xxx" (3 digits) appears in the display).
- Enter service code **253** by pressing the down button . Confirm by pressing . Note: If you enter the wrong code, you will be returned automatically to the "SERVICE" menu.
- Press arrow down or up until "MIN SUPP AIR" appears in the display.
- Confirm by pressing .
- The current setting appears in the display. The lamp change mode lamp comes on. Use arrow up/down to specify as a percentage of the unit's capacity, the volume of supply air that is planned. Adjustable between 19-50%.
- Confirm your selected setting by pressing .
- Check the new flow over the units. If necessary, make further adjustments to the capacities.
- If the minimum flow for exhaust air must also be adjusted, use the arrow keys until "MIN EX AIR" is shown on the display. The procedure is otherwise the same as for the supply air flow. Once the adjustment has been made, press the menu button to return to the main menu.

Adjusting exhaust air minimum flow

- In the main menu
- Press arrow down or up until "SERVICE SETTINGS" appears in the display.
- Confirm by pressing .
- "CODE xxx" (3 digits) appears in the display).
- Enter service code **253** by pressing the down button . Confirm by pressing . Note: If you enter the wrong code, you will be returned automatically to the "SERVICE" menu.
- If you enter the correct code, "SUPP AIR" appears in the display.
- Press arrow down or up until "MIN EX AIR" appears in the display.
- Confirm by pressing .
- The current setting appears in the display. The lamp change mode lamp comes on. Use arrow up/down to specify as a percentage of the unit's capacity, the volume of supply air that is planned. Adjustable between 19-50%.
- Confirm your selected setting by pressing .
- Check the new flow over the units. If necessary, make further adjustments to the capacities.
- If the minimum flow for exhaust air must also be adjusted, use the arrow keys until "MIN SUPP AIR" is shown on the display. The procedure is otherwise the same as for the supply air flow. Once the adjustment has been made, press the menu button to return to the main menu.

For the installer

Dimensioning diagram

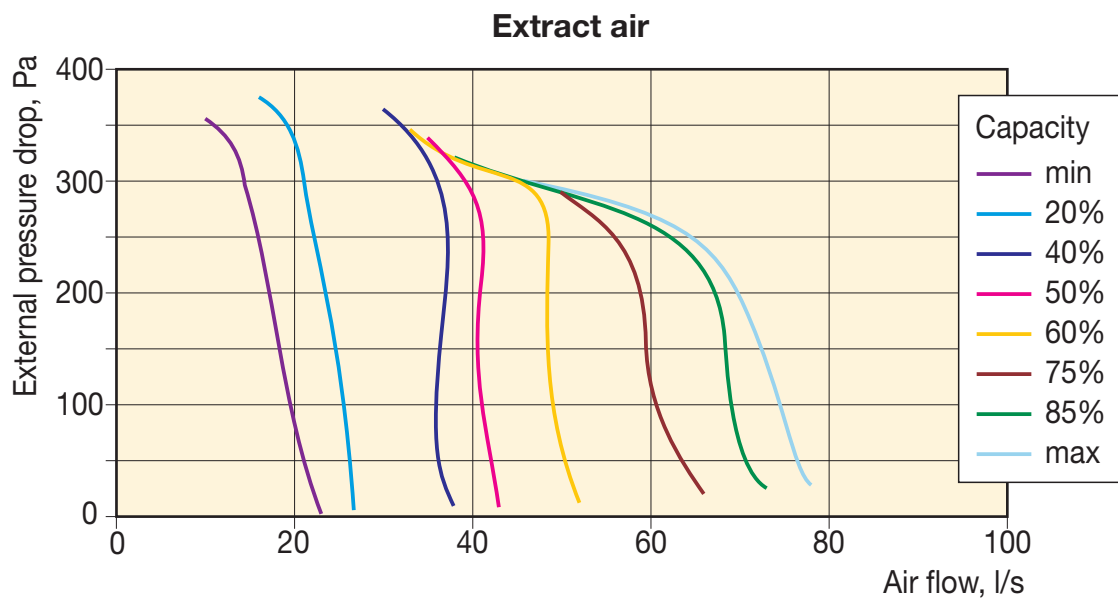
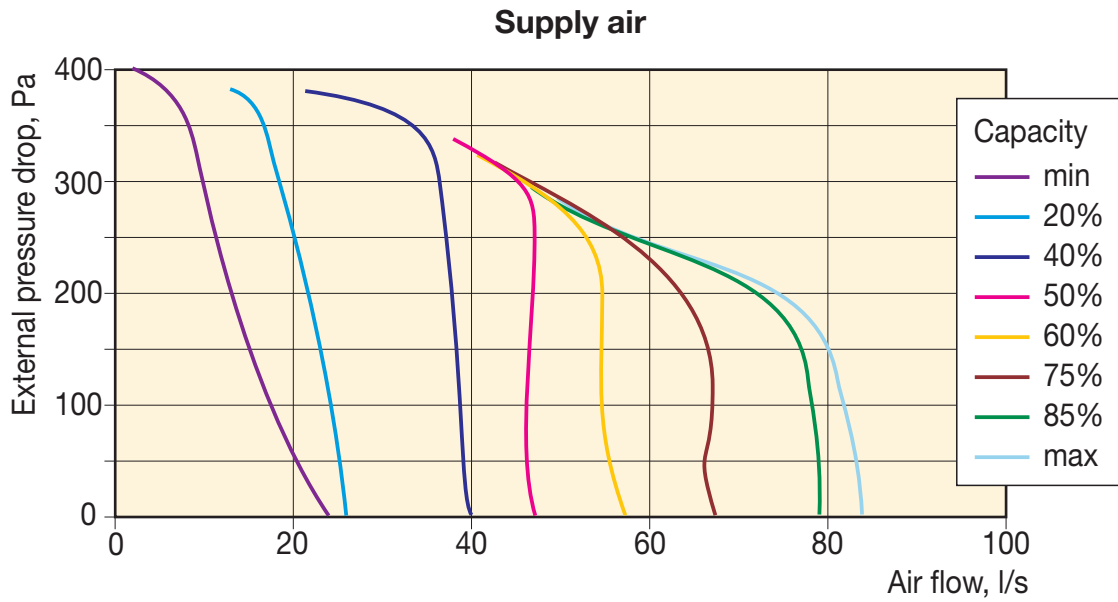

For the installer

Starting up/Adjustment

Starting the ventilation unit

- Check that the unit is fitted in accordance with our instructions
- Make sure that the condensation drain is connected and that condensation is able to run to a drain or floor drain. Open the service hatch in the lower part of the unit and check that the red plug is on the same side as the filters in the upper part of the unit. If the unit is fitted with the optional condensation evaporator (kavk), the condensation pipe will not be connected. Then check in the service hatch, in the lower part of the unit, that there is a red plug in the condensation drain on both sides of the partition wall.

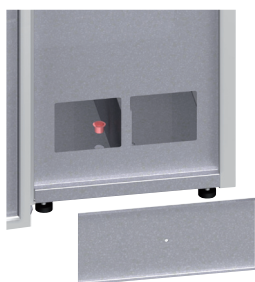

- Check that the duct system is fitted as shown in the planning documentation available for the installation.
- Switch on the power using the main switch in the control panel. “Main menu” appears in the display. This shows the set fan speed and the current air temperature at GT1. Leave the unit to run for a few minutes (approx. 5 min) to stabilise the values and carry out a self-diagnosis of its component parts. During this time, check that air is blowing out of all supply air devices and sucking out of all exhaust air devices.
- The ventilation system air flows should be adjusted by an authorised adjusting engineer. If you want to start up the unit, take care to ensure that the exhaust air flow is greater than the supply air flow. You can set the devices simply in their “middle modes”. Check also that the supply air devices are blowing and the exhaust air devices are sucking.

- Check the function of the afterheater by increasing the required room temperature in the control panel (for more info, see the section titled “Control panel”). There may be a small delay.
- Similarly, check the bypass function by reducing the required room temperature in the control panel. There may be a small delay.
- The bypass motor is checked by setting heat recovery to OFF. Check that the bypass valve opens (the valve movement is slow). For more info, see the section titled “Control panel”

Maintenance / Servicing

The information in the main menu may be replaced by alarm texts in order to provide a simple, user-friendly overview (in the event of any problems). These alarms are:

- 1. FILTER ALARM** = time interval for filter replacement has been exceeded (6 months).
- 2. HEATER ALARM** = overheating in the afterheater (at afterheater water - freezing - safety alarm).
- 3. FAN ALARM** = Indicates that the supply air or exhaust air fan is not functioning as it should.

To reset - see the section titled “Troubleshooting”.

For the installer

Maintenance/Serviceing

Renew filter

There are two filters in the Temovex unit: an exhaust air filter and an outdoor air (fresh air) filter. These filters should be replaced once a year as a minimum. The filters must not be washed - they must be replaced with new ones. Contact REC, +46 31 67 55 00, or see www.recvent.se to order filters.

- Switch off the power supply to the unit using the main switch.
- Open the door on the unit.
- Undo the long cover. Take hold of the filter and pull the front edge backwards and down.
- Behind the internal cover is the outdoor air (fresh air) filter. Remove this as well.
- If necessary, clean all accessible surfaces.
- Fit the new filters in reverse order. (The blue, exhaust air filter, is fitted in the front)
- Refit the cover
- Close the door to the unit
- Switch on the power.



The unit can be used if the filters are dirty, but its performance will be impaired. Energy consumption will increase and heat recovery will be reduced.

Note: When heat recovery is reduced, there is a risk of greater energy consumption to power the afterheater during cold periods. The unit must not be used without filters. This may cause damage to the fans and heat exchanger.











 The unit must not be used without filters. This may cause damage to the fans and heat exchanger.

New filters can be ordered from www.recvent.se or by calling REC, +46 31 67 55 00. REC also provides a subscription option for filters. All you have to do is decide how often you want to replace your filters, we do the rest. The filters will be sent to your home by post.

- It really couldn't be easier!

Subscribe at www.recvent.se today! State the production number of your unit and we will give you your first batch of filters free (subject to subscription to our service on the website).

Resetting the filter alarm

- In the main menu.
- Acknowledge the filter alarm by pressing **OK**. The text in the display and the lamp  goes out. Recurs at 7-day intervals.
- Press arrow down  or up  until "MANUAL SETTINGS" appears in the display 
- Confirm by pressing **OK**.
- Press arrow down  or up  until "FILTER RESET" appears in the display 
- Confirm by pressing **OK**.
- The display shows: "NO". Use the arrows   to select "YES" (replacement interval every 12 months)
- Confirm your selected setting by pressing **OK**.
- Press the menu button  to go back to the main menu.

Cleaning the fans

- Switch off the power using the main switch
- Open the door on the unit
- Remove both covers.
- Undo the quick-action contact on the fan and pull out the fan coil. (Take one fan at a time)
- Clean the impeller using a brush or compressed air.
- Refit the fans in reverse order.
- Refit the covers.
- Close the door to the unit.
- Switch on the power using the main switch.



 Under no circumstances must the motors be cleaned under running water.

For the installer

Maintenance/servicing

Cleaning the heat exchanger

- Switch off the power using the main switch.
- Open the door on the unit
- Remove both fans as described above.
- Open the service hatch at the bottom of the cabinet.

- Remove the red plug at the bottom of the unit, the condensation drain.
Note: Remember which side it should be on.
- Flush the heat exchanger with hot water. A degreasing agent may be required if the heat exchanger is very dirty. This must be of a type which is not aggressive to aluminium.

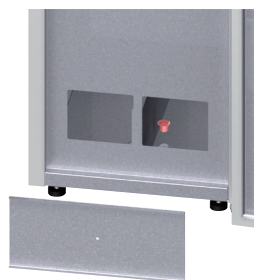

Note: If the unit is fitted with a condensation evaporator (kavk), a wet vac must be used to deal with the rinse water.

- Where necessary, repeat the procedure once more.
- Refit the red plastic plug. (This must be on the same side as the filters.)
- Refit the inspection hatch and fan motors in reverse order.



Take care to make sure the fan motors are not/do not get wet when restarting the unit-

This could be fatal!

- Close the door to the unit.
- Switch on the power using the main switch

Checking the condensation drain

- Open the door on the unit.
- Open the service hatch at the bottom of the cabinet
- Check the drain to make sure it is not blocked. This can be done by pouring a little water into the bottom of the unit, for example. NB: Only on the side without a plastic plug.
- In the event of a stoppage, try to remove the obstruction. Where necessary, call an engineer or plumber.
- Refit the service hatch
- Close the door to the unit.

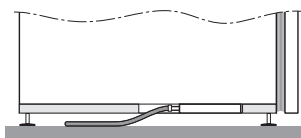

Cleaning the air diffusers

The building's ventilation devices must be cleaned regularly so as to maintain the correct ventilation. Use a dry cloth and/or a small brush in order to get into the ventilation outlet on the device. Where necessary, the device can be taken down to facilitate cleaning. The dirty mark which may appear on the ceiling near to the device can most easily be removed using a feather duster or dry cloth. Note: The device settings must not be changed. Do not confuse the devices if you take down a number of devices at the same time.



Cleaning the duct system

The exhaust air ducts - and in some cases the supply air

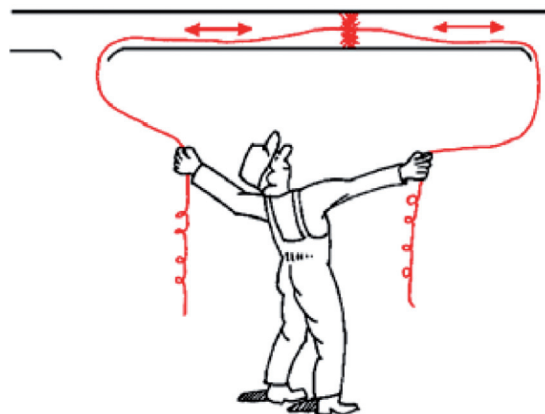

ducts as well - may need to be cleaned after a fairly long period of use. Dust and dirt collect there over time, and this can impair the system capacity.

Authorised ventilation cleaners should be called to carry out cleaning. However, the occupant can easily clean the first part of the system inside the device. Remove the device, then use a vacuum cleaner and - where appropriate - a feather duster to clean the bits you can get at.

Take care not to change the device settings.

Refit the device in the same location.

Note: Shut down the unit when cleaning devices or ducts.

Checking - outdoor air intake

It is a good idea to check the outdoor air intake once a year or so. Check that it is not blocked and that there is nothing obstructing it, such as leaves or snow/ice.

For the installer

Troubleshooting

1. “Filter alarm” appears in the display and the alarm lamp comes on

- a. Replace the filters and reset the filter alarm as described in an earlier instruction: see page 9.

2. The fan (fans) is (are) not running

- a. Check which fan is not running on the display. If there is power to the unit, continue as follows.
- b. If you think that any of the fans’ built-in overheat protection devices have tripped, shut off the power using the main switch on the unit. Wait approx. 1 minute before you switch the power back on again.
- c. Check that the plug is fully inserted; both into the wall and between the fan motors and the unit.
- d. If the fan (fans) is (are) still not running, or if they stop again after a short period of operation, contact a service engineer.
- e. Check that the unit fuse is unbroken.
- f. That the earth circuit breaker has not tripped.



2. Cold supply air

- a. Check that the bypass is not set to remain open constantly – set “heat recovery” to auto mode.
- b. Check that the exhaust air filter is not extremely dirty. – Where required, replace the filters.
- c. Check that the afterheater is not shut off – set the afterheater to AUTO.
- d. Check the temperature settings as shown in the instructions earlier on in this booklet.
- e. If the unit is fitted with the Cooling option,
 - Check its settings.

3. Low air quantity

- a. Check that the unit is operational. Check that the relevant fan is running.
- b. Check the settings for fan speed “SET MODE” – set to auto mode.
- c. Ensure that no external regulations/switches are affecting the fan speed.
- d. Check the air intake and roof hood. Clear away any dirt, snow, etc.
- e. Clean the fans and the heat exchanger where appropriate.
- f. If the devices or duct system are dirty – clean if necessary.
- g. Check that the duct system has not been deformed (during renovation or similar)



4. Water leaks

- a. Check that the condensation drain is connected to/is able to discharge to a floor drain.
- b. Check that there is no blockage in the condensation pipe from the unit.
- c. Check that the red plug inside the unit service hatch (lower part) is on the correct side. This should be on the same side as the filters. If the unit is fitted with a condensation evaporator unit (kavk), there is a plug in both holes.

5. Humming or noise from the unit

- a. Check whether any of the fan impellers is very dirty or otherwise damaged.
- b. If any of the impellers is dirty, this may cause imbalance – noise. Clean as described in the instructions.



6. Text alarm + alarm lamp

HEATER ALARM = overheating in the afterheater.

- Reset the heater’s internal overheat protector by switching off the power to the unit for approx. 3 min. Use the main switch on the unit. If the fault persists, contact a service engineers. The fans stop.
- Water afterheater, check that there is heat in the system and that the circulation pump is running. Reset the alarm by powering down the unit using the main switch for approx. 3 min.
- Check that the filters are not full of dirt and that the outdoor air intake is not blocked. The extract air (roof hood) may also need to be checked.
- Check the setting on the external thermostat GT7.

7. Sensor Error

If the duct sensor GT1 registers an incorrect or excessively deviating value, “Sensor Error” is shown on the display. The unit will subsequently stop regulating in relation to temperature until the error is corrected.

The status of outdoor air sensor GT11 is shown on the display under manual settings. In the same way, the value is displayed for GT3 (exhaust air sensor).

For the installer

Wiring diagram

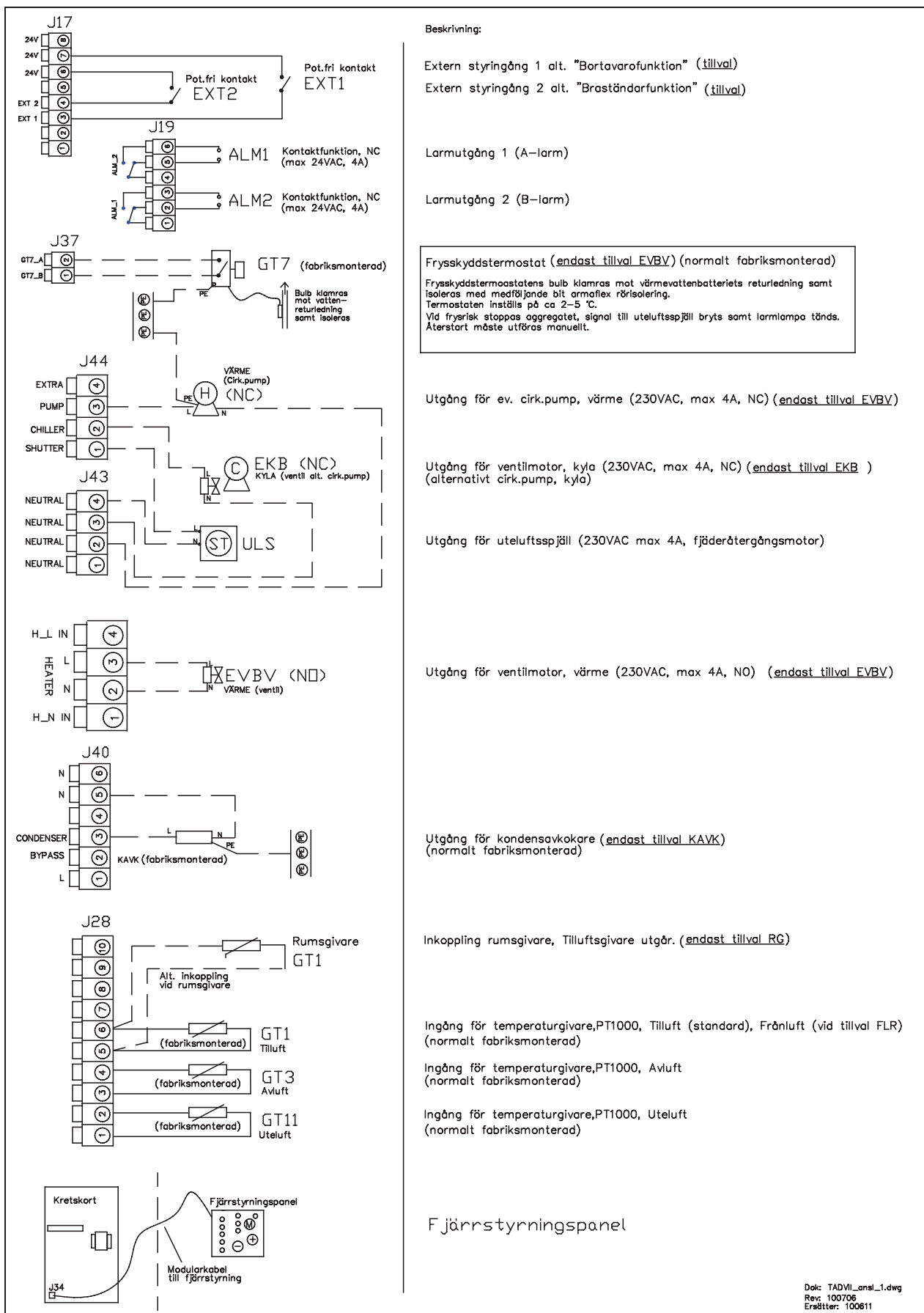

For the installer

REC-INDOVENT AB Advanced Parameterlista		Protokoll nr:	Aggregat model:
			Serie nr:
Objekt:	Hus/Lägenhet:	Programversion:	SET TEMP:
Notering			
MAN SETTING - HEATER		(OFF/AUTO)	
MAN SETTING - HTR SPAN		(1-5 grad)	
MAN SETTING - HEAT REC		(ON/OFF/AUTO)	
MAN SETTING - REC SPAN		(1-5 grad)	
Notering			
SERVICE - SUPP AIR		(20-85 %)	
SERVICE - EX AIR		(20-85 %)	
SERVICE - CLOCK 1		(NRM/STOP, NRM/LOW, NRM/MAX)	
SERVICE - CLOCK 2		(NRM/STOP, NRM/LOW, NRM/MAX)	
SERVICE - BP LIMIT		(5-30 grad)	
SERVICE - EXTERN 1		(NRM/STOP, NRM/LOW, NRM/MAX, ECO MODE)	
SERVICE - EXTERN 2		(NRM/STOP, NRM/LOW, NRM/MAX, L FIER)	
SERVICE - MIN SAIR		(19-50 %)	
SERVICE - MIN EAIR		(19-50 %)	
Noteringar:			
Datum:		Sign:	

Control panel

On the following pages you will find detailed instructions on how to set the unit according to your requirements and wishes. The unit control system optimises its function according to the settings you define.

As a user of the ventilation unit, you will find it useful to be aware of the following:

In menus where you have the option of making changes, “auto mode” gives the most optimised function. If you select a manual setting, On or Off, the manual setting takes precedence over the auto settings. **Push and briefly hold the buttons to implement changes.** You can also hold down a button longer to browse.

The lighting in the display turns on automatically when pushing a button and turns off again after about 1 minute of activity.



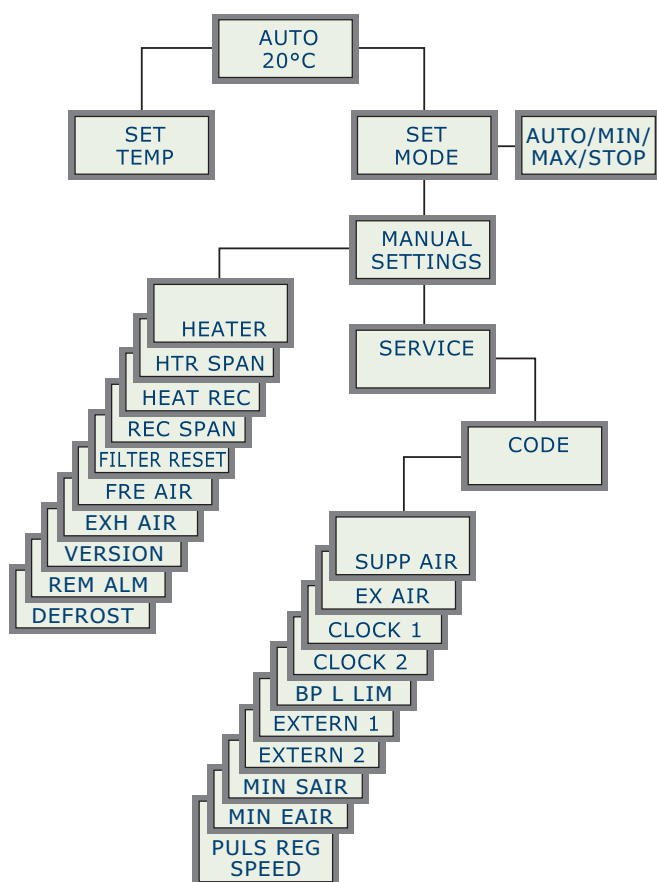

Menu structure

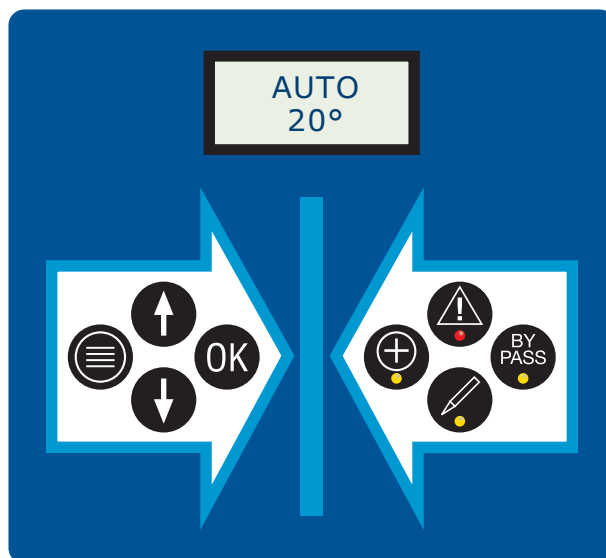





Structure/explanations



Buttons

-  Menu button, press to return to the main menu.
-  Arrow up, move up in menus or change mode
-  Arrow down, move down in menus or change mode
-  OK, confirm selected setting

Indicator lamps och symbols

-  Alarm, comes on when an alarm is triggered - look in the display for more detailed information
-  Bypass, comes on when the bypass is open (no recovery)
-  Afterheater, comes on when the afterheater is heating
-  Change mode, comes on when changes can be made

Display

- Fan speed selected
- Air temperature

Starting up/main menu

The display shows:

Line 1: current fan speed, min. flow/auto/max. flow



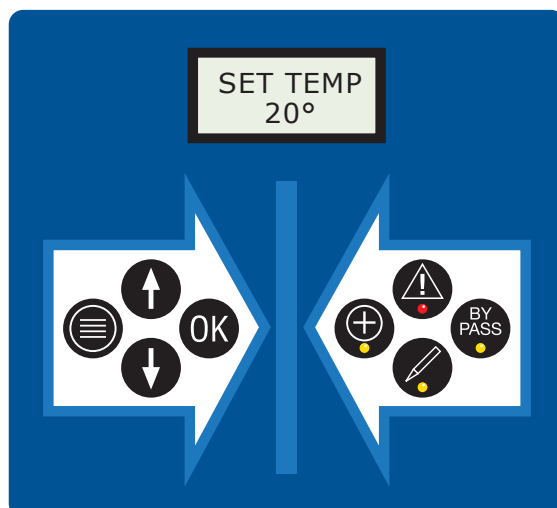

Line 2: actual air temperature in the supply air duct.

Note: As an alternative, sensors can be installed in exhaust air ducts or rooms.









Simple adjustments

Temperature, setting the temperature of incoming air (supply air)









- In the main menu
- Press **Pressure**  **OK**
- The display shows: “SET TEMP” and current setting. The change mode lamp  comes on. Press up  or down  to give the required value is displayed, in increments of 1 °C (set your required room temperature)
- Confirm your selected setting by pressing **OK**. This takes you back to the main menu, and current values are displayed

Changing operating mode, fan speed

- In the main menu
- Press arrow down  or up  until “SET MODE” appears in the display 
- Confirm by pressing **OK**, AUTO appears in the display.
- The change mode lamp  comes on. Use arrow up  or down  to switch between auto/min flow/max flow/stop system.
- Confirm your selected setting by pressing **OK**. This takes you back to the main menu.

Extended adjustments

Afterheater on/off (automatic if so required)

- In the main menu
- Press arrow down  up  until “MANUAL SETTINGS” appears in the display. 
- Confirm by pressing **OK**, “HEATER” appears in the display 
- Confirm by pressing **OK**. The current setting appears in the display. The change mode lamp  comes on. Use arrow up  or down  to choose between on/off (AUTO/OFF) 
- Confirm your selected setting by pressing **OK**.
- Press the menu button  to go back to the main menu.

Remote panel (option)

When the remote panel is connected, the text in the unit's control panel changes to "REMOTE".

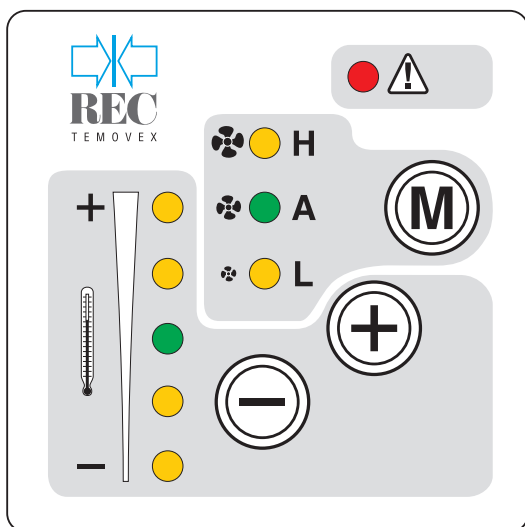

Structure/descriptions

⚠ The alarm LED indicates filter change.

(M) = Change fan speed: Auto, High or Low

(+) = Increase the temperature of supply air

(-) = Decrease the temperature of supply air

Temperature adjustment

By pressing (+) or (-) you can adjust the temperature of the supply air a few degrees up or down in relation to the setting in the unit's main panel.

Alarm indication





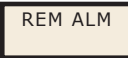





You can choose whether you want to have alarm indication on the unit or on the remote panel. When you switch on the power to the unit, the alarm lamp flashes once if alarms are displayed on the remote panel. To change, the M button must be depressed at the same time as the power is switched on. 3 flashes: Alarms on remote panel are off. 4 flashes: Alarms on remote panel are on. To reset the filter alarm from the remote panel, push and hold (M) and (-) (minus) at the same time; the lamp will flash 6 times.

Alarm indication on unit

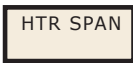











- On the main menu
- Press the down (↓) or up (↑) until the display shows "MANUAL SETTINGS". 
- Confirm with (OK).
- Press the down (↓) or up (↑) until the display shows "REM ALM". 
- Confirm with (OK).
- Displayen visar nuvarande inställning. The current setting is shown on the display. The change mode lamp (💡) comes on. Use the up/down arrows (↑/↓) to choose between YES/NO. NO provides indication on the unit. YES provides no indication on the unit.
- Confirm your selected setting with (OK).
- Press the menu button (☰) to return to the main menu.

Note: Through a combination of settings on the unit and/or remote panel, a situation can arise in which alarms are not displayed on either unit.

Regulation accuracy, afterheater

- In the main menu
- Press arrow down  or up  until "MANUAL SETTINGS" appears in the display 
- Confirm by pressing .
- Press arrow down  once until "HTR SPAN" appears in the display 
- Confirm by pressing .
- The current setting appears in the display. The change mode lamp  comes on. Use the arrows up/down  to change the value by 1-5 °C. State the deviation from set room temperature in "SET TEMP" before the afterheater is activated. (4 °C is recommended, e.g.: you require 21 °C indoors. So you set this value to 4.) 
- Confirm your selected setting by pressing .
- Press the menu button  to go back to the main menu.





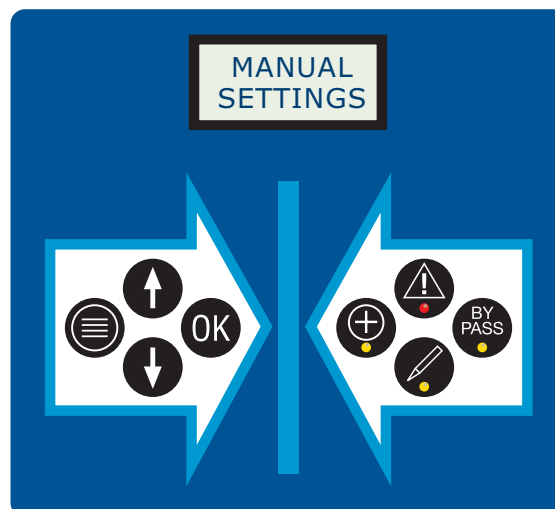







Heat recovery on or off

- In the main menu
- Press arrow down  or up  until "MANUAL SETTINGS" appears. 
- Confirm by pressing .
- Press arrow down  twice until "HEAT REC" appears in the display 
- Confirm by pressing .
- The current setting appears in the display. The lamp change mode lamp  comes on. Use the arrows up/down  to choose from on/off/auto (ON= heat recovery always on, OFF= heat recovery always off, AUTO= optimises the function guided by selected temperature settings) 
- Confirm your selected setting by pressing .
- Press the menu button  to go back to the main menu.



Setting summer bypass (bypass)

(Cooling recovery: Bypass closes to reuse subnormal temperature when the outdoor temperature exceeds the settings SET TEMP + REC SPAN)

- In the main menu
- Press arrow down  or up  until "MANUAL SETTINGS" appears.: 
- Confirm by pressing .
- Press arrow down  three times until "REC SPAN" appears in the display 
- Confirm by pressing .
- The current setting appears in the display. The lamp change mode lamp  comes on. Use the arrows up/down  to change the value by 1-5 °C. Specifies the deviation from the set room temperature in "SET TEMP" before the bypass opens (3 °C is recommended, e.g.: you require 21 °C indoors. So you set this value to 3.) 
- Confirm your selected setting by pressing .
- Press the menu button  to go back to the main menu.

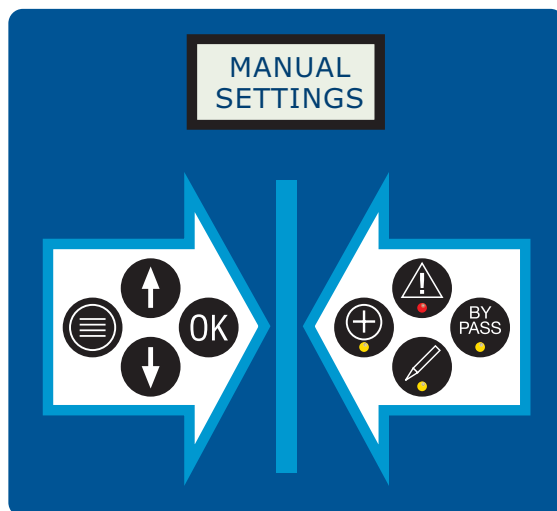

(when the cooling option is available, the menus “HEAT REC” and “REC SPAN” are replaced with settings “CHILLER” and “CHILSPAN” for cooling) Note: Unit fitted with the option chiller has no bypass.

Cooling on or off, optional

- In the main menu
- Press arrow down or up until “MANUAL SETTINGS” appears in the display
- Confirm by pressing .
- Press arrow down or up until “CHILLER” appears in the display
- Confirm by pressing .
- The current setting appears in the display. The lamp change mode lamp comes on. Use the arrows up/down to choose from off/auto (OFF = cooling is never activated, AUTO = optimises the function according to the selected temperature settings) ON = cooling always on
- Confirm your selected setting by pressing .
- Press the menu button to go back to the main menu.

Settings – cooling

- In the main menu
- Press arrow down or up until “MANUAL SETTINGS” appears in the display
- Confirm by pressing .
- Press arrow down or up until “CHILSPAN” appears in the display
- Confirm by pressing .
- The current setting appears in the display. The lamp change mode lamp comes on. Use the arrows up/down to change the value from 1-5. Specifies the deviation from the set room temperature in “SET TEMP” before cooling is activated (2 °C is recommended)
- Confirm your selected setting by pressing .
- Press the menu button to go back to the main menu.

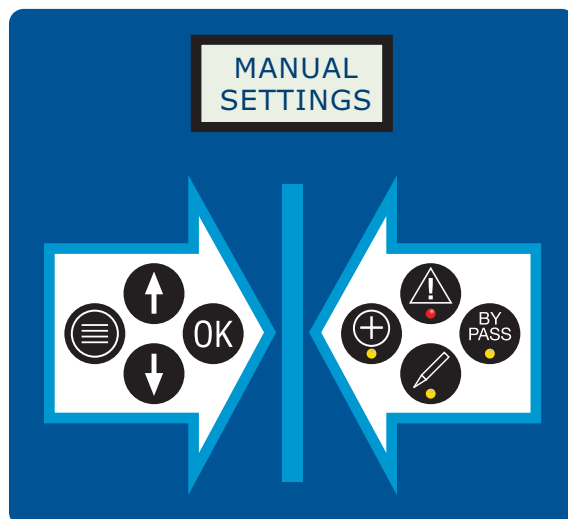

Resetting the filter alarm

- In the main menu.
- Acknowledge the filter alarm by pressing **OK**.
The text in the display and the lamp goes out. Recurs at 7-day intervals.
- Press arrow down **↓** or up **↑** until “MANUAL SETTINGS” appears in the display **MANUAL SETTINGS**
- Confirm by pressing **OK**.
- Press arrow down **↓** or up **↑** until “FILTER RESET” appears in the display **FILTER RESET**
- Confirm by pressing **OK**.
- The display shows: “NO”. Use the arrows **↑** **↓** to select “YES” (replacement interval every 12 months)
- Confirm your selected setting by pressing **OK**.
- Press the menu button **☰** to go back to the main menu.

Outdoor air temperature

- In the main menu
- Press arrow down **↓** or up **↑** until “MANUAL SETTINGS” appears in the display **MANUAL SETTINGS**
- Confirm by pressing **OK**.
- Press arrow down **↓** or up **↑** until “FRE AIR” appears in the display **FRE AIR**
- Confirm by pressing **OK**.
- The display shows the current temperature of the air being taken in from outside (fresh air) **FRE AIR 16°**
- Press **OK** to return to the submenu.
- Press the menu button **☰** to go back to the main menu.

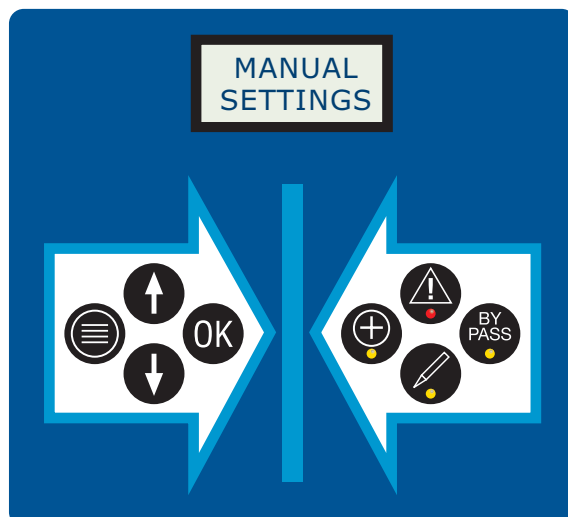

Extract air temperature

- In the main menu
- Press arrow down or up until “MANUAL SETTINGS” appears in the display
- Confirm by pressing .
- Press arrow down or up until “EXT AIR” appears in the display
- Confirm by pressing .
- The display shows the current temperature of the air being sucked out from the wet rooms
- Press to return to the submenu.
- Press the menu button to go back to the main menu.

MANUAL
SETTINGS

EXT AIR

EXT AIR
24°

Program version

- In the main menu
- Press arrow down or up until “MANUAL SETTINGS” appears in the display
- Confirm by pressing .
- Press arrow down or up until “VERSION” appears in the display
- Confirm by pressing .
- The display shows the software version installed in your unit
- Press to return to the submenu.

MANUAL
SETTINGS

VERSION

VERSION
XXX

- Press the menu button to go back to the main menu.

Defrosting

No defrosting is normally necessary on your ventilation unit. But if your operating conditions are such that the heat exchanger freezes over completely, you may need to activate the integrated defrosting function.

- In the main menu
- Press arrow down or up until “MANUAL SETTINGS” appears in the display
- Confirm with .
- Press arrow down or up until “DEFROST” appears in the display
- Confirm with .
- The display shows the current setting.
- To activate defrosting, change to ON using the arrows .
- Press to return to the submenu.
- Press the menu button to go back to the main menu.

MANUAL
SETTINGS

DEFROST

Defrosting is carried out through measurement of the exhaust air temperature. If the exhaust air temperature falls below the preset value (may not be changed) at any time during a 3-hour period, the unit will stop defrosting. The supply air fan stops and the bypass opening opens for about five minutes.

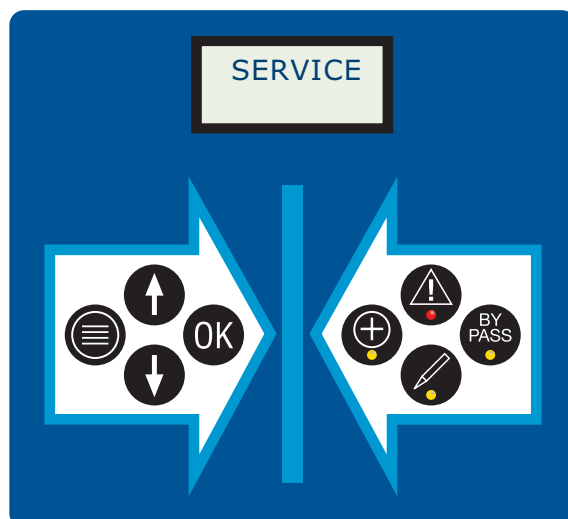

Adjusting the supply air flow

- In the main menu
- Press arrow down or up until "SERVICE" appears in the display
- Confirm by pressing .
- "CODE xxx" (3 digits) appears in the display
- Enter service code **253** by pressing the up/down buttons . Confirm by pressing .
Note: If you enter the wrong code, you will be returned automatically to the "SERVICE" menu.
- If you enter the correct code, "SUPP AIR" appears in the display
- Confirm by pressing .
- The current setting appears in the display. The lamp change mode lamp comes on. Use arrow up/down to specify as a percentage of maximum how much supply air is planned.
- Confirm your selected setting by pressing .
- Check the new flow over the devices. If necessary, adjust the capacity again.
- If the extract air flow also has to be adjusted, use the arrow keys to access "EX AIR" in the display. Otherwise the procedure is the same as for the supply air flow. If adjustment is complete, press the menu button to go back to the main menu.

Adjusting the extract air flow

- In the main menu
- Press arrow down or up until "SERVICE SETTINGS" appears.
- Confirm by pressing .
- "CODE xxx" (3 digits) appears.
- Enter service code **253** by pressing the up/down buttons. Confirm by pressing .
Note: If you enter the wrong code, you will be returned automatically to the "SERVICE" menu.
- If you enter the correct code, "SUPP AIR" appears in the display
- Press arrow down or up until "EX AIR" appears in the display
- Confirm by pressing .
- The current setting appears in the display. The lamp change mode lamp comes on. Use arrow up/down to specify as a percentage of maximum how much exhaust air is planned.
- Confirm your selected setting by pressing .
- Check the new flow over the devices. If necessary, adjust the capacity again.
- If the supply air flow also has to be adjusted, use the arrow keys to access "EX AIR" in the display. Otherwise the procedure is the same as for the exhaust air flow. If adjustment is complete, press the menu button to go back to the main menu.

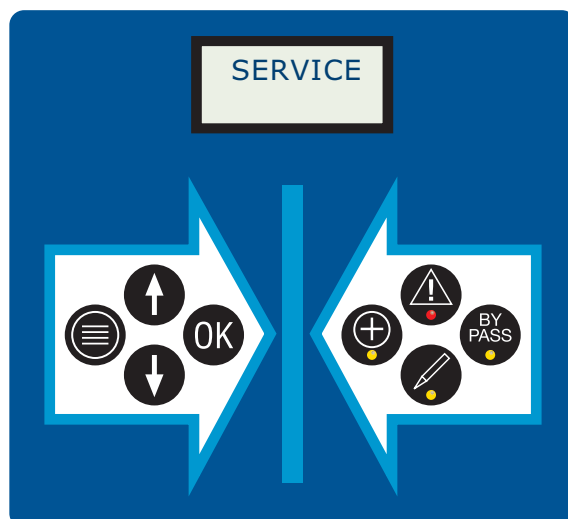

Adjusting supply air minimum flow

- In the main menu
- Press arrow down or up until "SERVICE" appears in the display.
- Confirm by pressing .
- "CODE xxx" (3 digits) appears in the display).
- Enter service code **253** by pressing the down button . Confirm by pressing . Note: If you enter the wrong code, you will be returned automatically to the "SERVICE" menu.
- Press arrow down or up until "MIN SUPP AIR" appears in the display.
- Confirm by pressing .
- The current setting appears in the display. The lamp change mode lamp comes on. Use arrow up/down to specify as a percentage of the unit's capacity, the volume of supply air that is planned. Adjustable between 19-50%.
- Confirm your selected setting by pressing .
- Check the new flow over the units. If necessary, make further adjustments to the capacities.
- If the minimum flow for exhaust air must also be adjusted, use the arrow keys until "MIN EX AIR" is shown on the display. The procedure is otherwise the same as for the supply air flow. Once the adjustment has been made, press the menu button to return to the main menu.

Adjusting exhaust air minimum flow

- In the main menu
- Press arrow down or up until "SERVICE SETTINGS" appears in the display.
- Confirm by pressing .
- "CODE xxx" (3 digits) appears in the display).
- Enter service code **253** by pressing the down button . Confirm by pressing . Note: If you enter the wrong code, you will be returned automatically to the "SERVICE" menu.
- If you enter the correct code, "SUPP AIR" appears in the display.
- Press arrow down or up until "MIN EX AIR" appears in the display.
- Confirm by pressing .
- The current setting appears in the display. The lamp change mode lamp comes on. Use arrow up/down to specify as a percentage of the unit's capacity, the volume of supply air that is planned. Adjustable between 19-50%.
- Confirm your selected setting by pressing .
- Check the new flow over the units. If necessary, make further adjustments to the capacities.
- If the minimum flow for exhaust air must also be adjusted, use the arrow keys until "MIN SUPP AIR" is shown on the display. The procedure is otherwise the same as for the supply air flow. Once the adjustment has been made, press the menu button to return to the main menu.

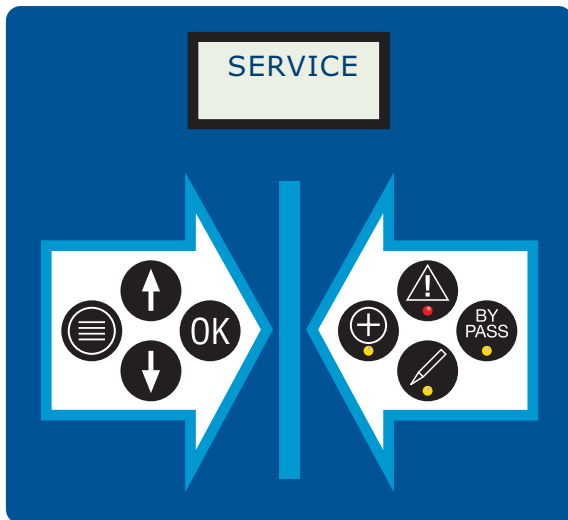

Bypass restriction (at low outdoor temperatures)

- In the main menu
- Press arrow down or up until "SERVICE" appears in the display
- Confirm by pressing .
- "CODE xxx" (3 digits) appears in the display
- Enter service code **253** by pressing the up or down button . Confirm by pressing .
Note: If you enter the wrong code, you will be returned automatically to the "SERVICE" menu.
- If you enter the correct code, "SUPP AIR" appears in the display
- Press arrow down or up until "BP L LIM" appears in the display
- Confirm by pressing .
- The current setting appears in the display. The lamp change mode lamp comes on. Use arrow up/down to set the required value, in increments of 1°C (between 5-30°C). 11°C is recommended.
- Confirm your selected setting by pressing .
- Press the menu button to go back to the main menu.

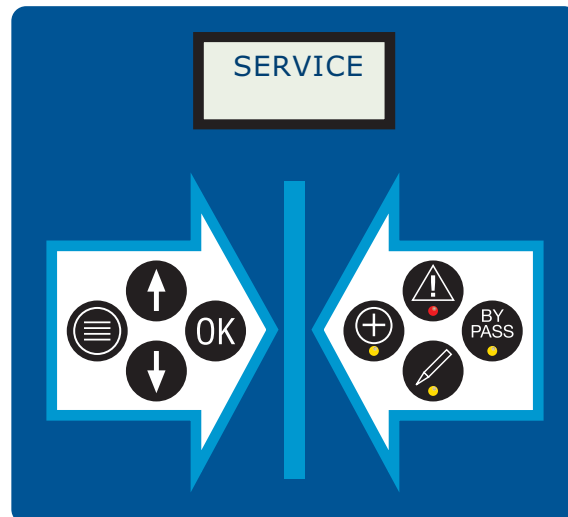

External control, input 1

Nrm/Stop, Nrm/Low, Nrm/Max, ECO MODE (optional)

- In the main menu
- Press arrow down or up until "SERVICE" appears in the display
- Confirm by pressing .
- "CODE xxx" (3 digits) appears in the display
- Enter service code **253** by pressing the up or down button . Confirm by pressing .
Note: If you enter the wrong code, you will be returned automatically to the "SERVICE" menu.
- If you enter the correct code, "SUPP AIR" appears in the display
- Press arrow down or up until "EXTERN 1" appears in the display
- Confirm by pressing .
- The current setting appears in the display. The lamp change mode lamp comes on. Use arrow up/down to choose from NRM/STOP, NRM/LOW, NRM/MAX or ECO MODE (optional).
- Confirm your selected setting by pressing .
- Press the menu button to return to the main menu.

External control, input 2

Nrm/Stop, Nrm/Low, Nrm/Max, L FIRE (optional)

- In the main menu
- Press arrow down or up until "SERVICE" appears in the display
- Confirm by pressing .
- "CODE xxx" (3 digits) appears in the display
- Enter service code **253** by pressing the up or down button . Confirm by pressing .
Note: If you enter the wrong code, you will be returned automatically to the "SERVICE" menu.
- If you enter the correct code, "SUPP AIR" appears in the display
- Press arrow down or up until "EXTERN 2" appears in the display
- Confirm by pressing .
- The current setting appears in the display. The lamp change mode lamp comes on. Use arrow up/down to choose from NRM/STOP, NRM/LOW, NRM/MAX or L FIRE (optional).
- Confirm your selected setting by pressing .
- Press the menu button to return to the main menu.

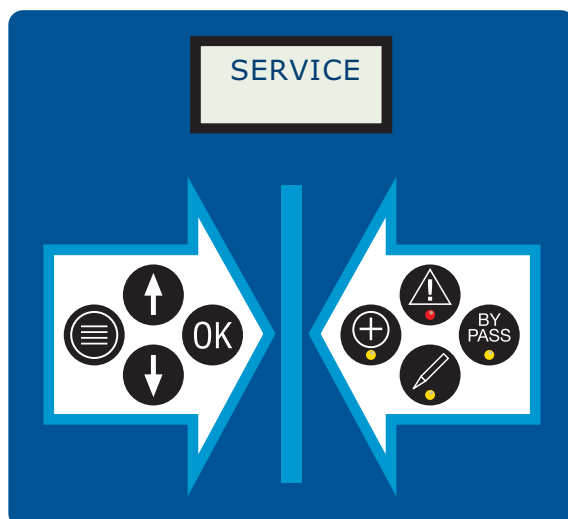

Timer functions, channel 1 (option)

- In the main menu
- Press arrow down or up until "SERVICE" appears in the display
- Confirm by pressing .
- "CODE xxx" (3 digits) appears in the display
- Enter service code **253** by pressing the up or down button . Confirm by pressing .
Note: If you enter the wrong code, you will be returned automatically to the "SERVICE" menu.
- If you enter the correct code, "SUPP AIR" appears in the display
- Press arrow down or up until "CLOCK 1" appears in the display
- Confirm by pressing .
- The current setting appears in the display. The lamp change mode lamp comes on. Use arrow up/down to choose from NRM/STOP, NRM/LOW or NRM/MAX
- Confirm your selected setting by pressing .
- Press the menu button to go back to the main menu.

Timer functions, channel 2 (option)

- In the main menu
- Press arrow down or up until "SERVICE" appears in the display
- Confirm by pressing .
- "CODE xxx" (3 digits) appears in the display
- Enter service code **253** by pressing the up or down button . Confirm by pressing .
Note: If you enter the wrong code, you will be returned automatically to the "SERVICE" menu.
- If you enter the correct code, "SUPP AIR" appears in the display
- Press arrow down or up until "CLOCK 2" appears in the display
- Confirm by pressing .
- The current setting appears in the display. The lamp change mode lamp comes on. Use arrow up/down to choose from NRM/STOP, NRM/LOW or NRM/MAX
- Confirm your selected setting by pressing .
- Press the menu button to go back to the main menu.

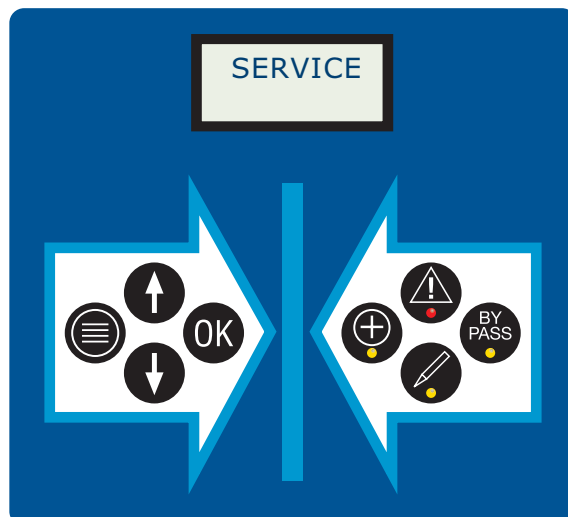

Pulse regulation (option)

- In the main menu
- Press arrow down or up until "SERVICE" appears in the display
- Confirm by pressing .
- "CODE xxx" (3 digits) appears in the display
- Enter service code **253** by pressing the up or down button . Confirm by pressing .
Note: If you enter the wrong code, you will be returned automatically to the "SERVICE" menu.
- If you enter the correct code, "SUPP AIR" appears in the display
- Press arrow down or up until "PULS REG SPEED" appears in the display
- Confirm by pressing .
- The current setting appears in the display. The lamp change mode lamp comes on. Use arrow up/down to choose between 1–10; 1 provides rapid regulation (suitable for supply air regulation) and 10 significantly slower.
- Confirm your selected setting by pressing .
- Press the menu button to go back to the main menu.

REC Indovent reserves the right to make changes to the specification and design with no prior notification.



REC Indovent AB

Box 37, SE-431 21 Mölndal, Sweden

Visiting address: Kärragatan 2

Tel: +46 31 67 55 00

Fax: +46 31 87 58 45

www.rec-indovent.se



REC-10-11-18

www.ejeform.com 100220